

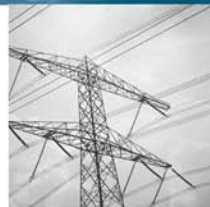

DELTA MCS-1800 Power Shelf

**Installation, Operation and
Maintenance Manual**

Telecom Power
System



Delta MCS 1800 3U Power Shelf

**Installation, Operations and
Maintenance Manual**



Table of Contents

1. General	-----	1-1
1.1 Using This Manual	-----	1-1
1.2 Safety Notice	-----	1-1
2. Product Description	-----	2-1
2.1 Product Description	-----	2-1
2.2 Product Main Features	-----	2-1
2.3 System Specifications	-----	2-1
3. Power Supply Unit (PSU)	-----	3-1
3.1 Description	-----	3-1
3.2 Specifications	-----	3-1
3.3 Operation and Adjustment	-----	3-4
3.4 System Alarm	-----	3-5
3.5 PSU Block Diagram	-----	3-5
3.6 PSU Operating Principle	-----	3-5
4. Alarm Control Unit	-----	4-1
4.1 Description	-----	4-1
4.2 Specifications	-----	4-1
4.3 Alarm Control Unit Block Diagram	-----	4-4
4.4 Settings and Control	-----	4-4
5. DC Distribution	-----	5-1
5.1 DC Cabling	-----	5-1
5.2 Low Voltage Battery Disconnect (System equipped with PDU)	-----	5-1
5.3 Battery Connections (System equipped with PDU)	-----	5-1
5.4 Battery Temperature Probe Connection (System equipped with PDU)	-----	5-1
6. Installation	-----	6-1
6.1 Preliminary Inspection	-----	6-1
6.2 System Mounting	-----	6-1
6.3 Module Installation	-----	6-1
6.4 Shelf Wiring	-----	6-1
6.5 AC Input Connections	-----	6-1

Table of Contents

6.6	Battery String Connections (System equipped with PDU)	6-1
6.7	Temperature and Alarm Connections	6-2
6.8	EXT. Breaker trip signal I/P Connector Wiring	6-2
6.9	AC High Voltage Aux. Relay Output Wiring	6-2
7.	System Start –Up Procedure	7-1
7.1	Initial Start-Up Preparation	7-1
7.3	Basic Functional Verification 7.2 No Load Start-Up	7-1
7.4	DC Load Connections	7-1
7.5	System Functionality Check	7-1
7.6	System Operation	7-1
8.	System Alarms and Troubleshooting	8-1
8.1	AC Fail Voltage Alarm Description	8-1
8.2	High Voltage Shutdown Alarm	8-1
8.3	High Voltage Alarm Description	8-1
8.4	Low Voltage Alarm	8-2
8.5	Low Voltage Disconnect Alarm (System equipped with PDU)	8-2
8.6	Fuse Fail Alarm (System equipped with PDU)	8-2
8.7	Alarm Unit Fail	8-3
8.8	Rectifier Fail Alarm	8-3
9.	Maintenance	9-1
9.1	Cleaning and Maintenance	9-1
9.2	Removing and Replacing a Rectifier Unit	9-1
10.	Acronyms and Abbreviations	10-1 ~3

ATTACHMENT

1 General

1.1 Using This Manual

This manual contains specifications and instructions to properly install and maintain the power supply system. Component specifications and drawings are also included.

This manual contains information related to the operation and maintenance of the Alarm Control Unit (ALU), the -48V/+24V Power Supply Unit (PSU), and the Distribution Module. Additional information is provided on system status and alarms, troubleshooting, and system maintenance. Appendix figures of this manual contains drawings, simple block diagram for different functional blocks and systems schematic.

Step-by-step procedures required for the installation and turn-up are detailed. All equipment parameter setting, adjustments, and confirmation, as well as system monitoring, operations, and maintenance procedures, are included.

Warnings are printed in bold, italic lettering. They alert the installation or maintenance craftsperson of a potential hazard to either the equipment or the craftsperson if the warning is not followed.

1.2 Safety Notice

Delta Energy Systems is not liable for any hazards incurred by not following proper safety procedures. Installation, operation, and maintenance personnel should always follow these safety rules:

1. Before installing the system, verify the AC input voltage and frequency, the AC breaker rating and type, and other environmental conditions as noted in the specifications.
2. The system has passed stringent system testing prior to shipment. To avoid electrical shock. The rectifier system requires a single ground point permanently connected to earth ground.
3. An AC breaker must provide adequate isolation between the system input and commercial AC main.
4. The environment should be dust free and controlled by an AC system. The area must be free of any flammable vapors or fluids.
5. To avoid electrical hazard, the covers must not be removed on any component, including the ALU and the rectifier.
6. Circuit breakers or fuses must be replaced with approved replacement circuit breakers meeting the original design specification.
7. All connections must be made per the latest issue of the applicable national and local codes.

2 Product Description

2.1 Product Description

This power Shelf consists of modular rectifiers, an Alarm Control Unit (ALU), and a DC distribution module. Up to four rectifiers and an alarm unit can be equipped on a shelf containing an integrated distribution module. The rectifiers can operate from a universal range of AC line voltages. The High Line (HL) operations are defined at an AC line input range of 165VAC~ 264VAC. The Low Line (LL) operations are defined at an AC line input range of 90 VAC-130 VAC.

The system is controlled and monitored by the ALU. System level rectifier voltage settings, system status, and alarms are displayed on the ALU. The system float voltage, equalize voltage, and alarm thresholds are set from RMS. The ALU also provides automatic derating of the output power over the whole operating line voltages. Figure 1 shows different functional blocks of the system.

2.2 Product Main Features

The Power Shelf has the following main features:

- -48 VDC/120 Amps, or +24VDC/200Amps, N+1 redundancy
- Modular design for scalable, cost effective expansion
- Front access for simple installation and maintenance
- High power density
- Active Power Factor Correction (>. 99PFC)
- High efficiency
- Temperature compensated float voltage control
- Alarm Control Unit
- Low Voltage Battery Disconnect (LVBD) (System equipped with PDU)
- Remote Monitoring and control

2.3 System Specifications

The system specifications are provided in the following sections.

2.3.1 -48V Standard Power Shelf Configuration(MODUL NAME: ES48/120-JAxx)

- | | |
|----------------------------------|------------------------------|
| (1) AC Input: | 175VAC ~ 275VAC, 48Amps. Max |
| (2) System Capacity: | 120Amps. Max. |
| (3) Rectifier: | -48V/30A×1~4 |
| (4) Control and Supervisory Unit | |

Figure 1 shows a front view of shelf.

Environmental Data

System Environmental Data

Specification	Value
Operating temperature	0°C to +50°C
Storage temperature	-40°C to +70°C
Humidity	0% to 95% RH
Altitude	-300 ft. to 10,000 ft.
Weight	Approximately 48 lbs.
EMI/FRI	FCC Part 15, Class B and CISPR 22, Class B
Lightning/surge	ANSI/IEEE C62.41-1, and IEC 1000-4-5
Seismic	Bellcore GR-63-CORE, Zone 4
Safety	CUL and UL Listed and Marked

2.3.2 +24V Standard Power Shelf Configuration(MODUL NAME: ES24/200-JAxx)

- (1) AC Input: 175VAC ~ 275VAC, 48Amps. Max
- (2) System Capacity: 200Amps. Max.
- (3) Rectifier: +24V/50A×1~4
- (4) Control and Supervisory

Figure 1 shows a front view of shelf.

Environmental Data

System Environmental Data

Specification	Value
Operating temperature	0°C to +50°C
Storage temperature	-40°C to +70°C
Humidity	0% to 95% RH
Altitude	-300 ft. to 10,000 ft.
Weight	Approximately 48 lbs.
Lightning/surge	ANSI/IEEE C62.41-1, and IEC 1000-4-5
Seismic	Bellcore GR-63-CORE, Zone 4
Safety	CUL and UL Listed and Marked

2.3.3 -48V System with Power Distribution and Rectifiers(MODUL NAME: ES48/90-JBAxx)

- (1) AC Input: 175VAC ~ 275VAC, 36Amps. Max
- (2) System Capacity: 90Amps. Max.
- (3) Rectifier: -48V/30A×1~3
- (4) Control and Supervisory
- (5) Load Distribution: 30A Breaker×5 @ Single Pole
- (6) Low Voltage Disconnect Switch: 100A×1 @ Single Pole at Battery Side
- (7) Battery Breaker: 100A×1
- (8) AC Breaker

Figure 1-1 shows a front view of shelf.

Environmental Data

System Environmental Data

Specification	Value
Operating temperature	0°C to +50°C
Storage temperature	-40°C to +70°C
Humidity	0% to 95% RH
Altitude	-300 ft. to 10,000 ft.
Weight	Approximately 48 lbs.
Lightning/surge	ANSI/IEEE C62.41-1, and IEC 1000-4-5
Seismic	Bellcore GR-63-CORE, Zone 4

2.3.4 -48V System with Power Distribution and Rectifiers(MODUL NAME: ES48/90-JFAxx)

- (1) AC Input: 175VAC ~ 275VAC, 36Amps. Max
- (2) System Capacity: 90Amps. Max.
- (3) Rectifier: -48V/30A×1~3
- (4) Control and Supervisory
- (5) Load Distribution: 100A Breaker×4 @ Single Pole
- (6) Low Voltage Disconnect Switch: 100A×1 @ Single Pole at Battery Side

Figure 1-1 shows a front view of shelf.

Environmental Data

System Environmental Data

Specification	Value
Operating temperature	0°C to +50°C
Storage temperature	-40°C to +70°C
Humidity	0% to 95% RH
Altitude	-300 ft. to 10,000 ft.
Weight	Approximately 48 lbs.
EMI/FRI	FCC Part 15, Class B and CISPR 22, Class B
Lightning/surge	ANSI/IEEE C62.41-1, and IEC 1000-4-5
Seismic	Bellcore GR-63-CORE, Zone 4
Safety	CUL and UL Listed and Marked

2.4 Electrical Data

The system electrical data is provided in the following tables.

2.4.1 Input

Table 1 displays the system input specifications.

Table 1 System Input Specifications

Specification	Value
Nominal range	175 ~ 275VAC
Operational range	90 ~ 275VAC Full Load
	150V ~ 175Vac de-rating to 80% Load
	90V ~ 150Vac de-rating to 50% Load
	50°C ~ 65°C de-rating 1500W
Frequency	45 ~ 65Hz
Power Factor	>0.99 @ 220VAC, Full Load
THD	<5% @ 220VAC, Full Load
Efficiency	>90% @ 220VAC, Full Load

2.4.2 Output

Table 2 displays the system output specifications.

Table 2 System Output Specifications

Specification	Value
DC Volts	38~60 VDC (-48V Version) 20~30 VDC (+24V Version)
Load regulation	<1%
Line regulation	<0.2%
Current Limit	110%
Current share	<5%
Noise:	
Audio band	<2mv
Wide band	<10 mVrms
Acoustic	<55 dBA

2.4.3 Status/Alarm Indicators

The Power Shelf has the following status/alarm indicators:

- Load Current
- AC ON
- Rectifier Fail Alarm (RFA)
- Current Limit (CL)
- Float/Equalize (FL/EQU)
- Major Alarm (MAJ)
- Minor Alarm (MIN)
- High Voltage Alarm (HV)
- High Voltage Shutdown (HVSD)
- Low Voltage Alarm (LV)
- Low Voltage Disconnect Open (LVDS OPEN)
- Fuse Blown (FUSE ALM)
- AC Fail (AC FAIL)

2.4.4 Mechanical Data

Dimension	Value
Height	5.2 in. (132mm)
Depth	10.35 in. (263mm)
Width	3.3 in. (83.6mm)

3 Power Supply Unit (PSU)

3.1 Description

This rectifier units are rated at full load when operated from high line. For Low operation, the output is derated to half load. This derating is automatically activated from the Alarm Control Unit (ALU). However, the rectifier can operate on a stand-alone basis, if this ALU is removed or nonfunctional.

Warning: *In the absence of the ALU, the automatic derating of the rectifiers at Low Line is not effective. Exceeding the 50% load limit at Low Line may damage the rectifiers.*

The modular design provides the flexibility to configure and expand the system as the load demand increases. Each rectifier unit is swappable with front access for ease of maintenance without system shutdown, providing uninterrupted service.

The rectifier unit has an active power factor correction of greater than 0.99 for maximum AC utilization. Each module is equipped with an AC switch located at the front of the module. Figure 3 shows a front view of PSU.

Note: *The equipment is only for installation in a Restricted Access Location.
The equipment is used on a stationary equipment/unit only.*

3.2 Specifications

Detailed rectifier specifications are provided in the following sections.

3.2.1 Electrical

Detailed electrical specifications for the rectifier are provided in this section.

3.2.1.1 Input

Table 6 displays the rectifier input specifications.

Table 6 Rectifier Input Specifications

Specification	Value
Input Voltage	90VAC to 275VAC, Single Phase, (during 176 to 150VAC derated to 80% Load, during 150 to 90VAC derated to 50% Load)
Input Current	12 Amps at 176 VAC, Full Load
Line Frequency	45 to 65 Hz
Power Factor	>0.99, at 220 VAC Input, Full Load
THD	<5%, at 220 VAC Input, Full Load
Efficiency	>90%, Full Load (-48V Version) >88%, Full Load (+24V Version)
Inrush Current	<12 Amps (peak), 220 VAC, Full Load, Cold Start
Start Time Delay (Walk-In)	3 to 10 seconds
Protection	Fuse

3.2.1.2 Output

Table 7 displays the rectifier output specifications.

Table 7 Rectifier Output Specifications

Specification	Value
DC Output Voltage	40 to 60VDC [factory preset at -54.3VDC, 30Amps (HL) / 15Amps (LL)] -48V Version 20 to 30VDC [factory preset at 27.2VDC, 50Amps (HL) / 25Amps (LL)] +24V Version
Output Power	1800W Maximum (-48V Version) 1500W Maximum (+24V Version)
Regulation:	
Load	<1% (Load 0 to 100%)
Line	<0.1%
Current Limit	110% Max. of Rated Output Current
Noise:	
Audio Band	<2mV
Wide Band	<20 mVrms (10 KHz to 100 MHz)
Acoustic	<55 dBA @ 1M
Current Sharing	<5% of Rated Output Current
Dynamic Response	10% to 90% Load Change Overshoot ≤5% Rated Output Voltage Recovery Time <1 ms to ≤1% Rated Output Voltage
Protection	Fuse

3.2.1.3 Protection

Table 8 displays the protection specifications.

Table 8 Protection Specifications

Condition	Response
High Output Voltage (Exceeds Preset Value)	Automatic Shutdown and Latch
Over Current/Output Short	Automatic Shutdown and Recovery
Over Temperature	Automatic Shutdown and Recovery
Brownout	No Damage
AC Input Voltage High	Automatic Shutdown and Recovery
AC Input Voltage Low	Automatic Shutdown and Recovery

3.2.1.4 Adjustments

Table 9 displays the adjustments.

Table 9 Adjustments

Adjustment	Description
Test Points (I+,I-)	Current
Float Voltage (FLO)	Variable Resistor or Setting on ALU
Current Limit (CL)	Variable Resistor or Setting on ALU

3.2.2 Environmental

Table 10 displays the environmental specifications.

Table 10 Environmental Specifications

Specification	Value
Operating temperature	32 to +122°F (0°C to +50°C) OPTION
Storage temperature	-40 to +185°F (-40°C to +85°C)
Humidity	0% to 95% Relative Humidity No condensing
Altitude	-5.2"/132mm
Weight	3.3 Kg (7.26 lbs.)
EMI/FRI suppression	Conforms to EN 55022, BS 6527 FCC Part 15 Subpart J, and CISPR 22 Class A
Current harmonic	Conforms to EN 61000-3-2/A12, EN 60555-2, IEC 1000-3-2 Class A
Voltage fluctuation	Conforms to EN 61000-3-3M, EN 60555-3
Electrostatic discharge	Conforms to EN 61000-4-2, IEC 1000-4-2, IEC 801-2 Level 4
Radiated susceptibility	Conforms to IEC 1000-4-3, IEC 801-3 Level 3
Electrical fast transients	Conforms to EN 61000-4-4, IEC 1000-4-4, IEC 801-4 Level 4
Conducted susceptibility	Conforms to IEC 1000-4-6 Level 3
Lightning/surge	Conforms to ANS/IEEE C62.41.-1, 1991 B3, IEC 1000-4-5 Level Special (6KV)
Safety	Meets IEC 950, EN60950, UL/C ^{UL} /CE Approval
MTBF	>150 K hours
Cooling	Fan cooling
Heat dissipation	682 BTU/hour max. per module (-48V Version) 698 BTU/hour max. per module (+24V Version)

3.2.3 Status/Alarm Indicators

Table 11 displays the status alarm indicators

Table 11 Status Alarm Indicators

Indicator	Color	Function	Description
LED	Amber	CL	Current Limit
LED	Green	AC	AC ON
LED	Red	RFA	Rectifier Failure Alarm

3.2.4 Mechanical Data

Table 12 displays the rectifier mechanical data.

Table 12 Rectifier Mechanical Data

Dimension	Value
Height	5.2 in. (132mm)
Depth	10.35 in. (263mm)
Width	3.3 in. (83.6mm)

3.3 Operation and Adjustment

All operating adjustments are made at the front panel of each rectifier. The following components are located on each rectifier panel:

1. Float voltage adjustment
2. Current limit adjustment
3. Current test points
4. Alarm indicators

Figure 3 shows different indicators and adjustment points on this unit.

Rectifier adjustments must be done sequentially from the first through the fourth rectifier with AC applied. All adjustments must be made with no load, and the batteries disconnected to ensure adjustment accuracy.

3.3.1 Start-Up

To start up the system, perform the following steps:

1. Approximately 3 to 8 seconds after the AC applied, the RFA LED extinguishes.

3.3.2 Float Voltage Adjustment

Verify the required float voltage setting per battery manufacturer specification. If the factory setting differs from the battery manufacturer recommended setting, the ALU float voltage parameter and each rectifier's float voltage must be adjusted to the new setting. A digital multimeter and a small screwdriver are required to perform this procedure. Located the float voltage access point (FL) at the front of the rectifier.

To adjust the float voltage, perform the following steps:

1. Remove the ALU.

2. Place the digital multimeter probe in the V+ and V- output voltage connector.
3. Adjust the float voltage by using a screwdriver to turn the FL point to the voltage value as shown on the meter. The tolerance error should not exceed 0.02V.

Notes:

1. Turning the variable resistor adjustment point clockwise increases the value, and counterclockwise
2. Refer to Figure 3 (rectifier front view) for the location of V+, V- and FL point.
3. When the setting is completed, temperature and voltage compensation must be reset to the default value.

3.3.3 Current Limit Setting

Warning: *Current limit setting is not intended to be adjusted in the field. Users should only use it for their reference.*

Current limit adjustment is made by turning the CL variable resistor with the digital multimeter probes in the I+, I- test points. This current limit is set at the factory. The factory setting is always the maximum value of 110%. For a 48V/30 Amp rectifier, the computation for the current limit is $1.1 \times 30 = 33$ Amps.

The following adjustment procedure is for reference only:

1. At the rectifier, place the digital multimeter probes in the I+, I- test points.
2. Place a small screwdriver in the CL adjustment point.
3. Turn the variable resistor counterclockwise to increase the value. Turn the variable resistor clockwise to decrease the current limit value.

3.4 System Alarm

During an alarm condition, the faulty rectifier illuminates its RFA light on the front panel. The rectifier fail alarm signal is sent to the ALU, which processes the alarm, closes the RFA alarm contacts, and lights the alarm LEDs.

3.5 PSU Block Diagram

Refer to Figure 5.

3.6 PSU Operating Principle

After applying the incoming line voltage to the rectifier, current is applied to the EMI filter and circulates through protection components such as the AC circuit breaker and the fuse. The major functions of the protection devices are to prevent the rectifier from being damaged by surge voltage, to efficiently reduce the noise of differential mode and common mode, to eliminate the high frequency noise from input current, and to prevent noise reverse to the source circuit.

The AC input voltage is rectified and converted to a 400VDC bus through a PFC boost stage. This PFC stage maintains the Power Factor at $>.99$ and the Total Harmonic Distortion (THD) at $<5\%$.

The 400 VDC bus voltages is modulated at a frequency higher than 100KHz and stepped down through a transformer. Output of this transformer is rectified and filtered to provide the output DC voltage.

4 Alarm Control Unit

4.1 Description

The Alarm Control Unit (ALU) with RS232 & LAN interface and remote monitoring function provides output alarms, alarm threshold adjustments, float and equalize voltage adjustments, temperature compensation voltage settings, low voltage disconnect voltage threshold settings, an equalize charge timer, and system alarm LEDs. In addition, the ALU automatically derates the system output current according to the following table:

Figure 2 shows a front view of Alarm control unit.

Table 13 Voltage Ranges

Input Voltage Range	Output
90-150 VAC	50%
150-175 VAC	80%
176-275 VAC	100%

The module is hot swappable.

4.2 Specifications

4.2.1 Input Characteristics

Table 14 displays the input characteristics.

Table 14 Input Characteristics

Characteristic	Value
Input Voltage Range	40V to 59.5V for 48V system 20V to 30V for 24V system
Input Current	<0.5 Amps

4.2.2 Push Buttons

This alarm unit has 3 push buttons on the front panel. These push buttons are used to control the alarm unit. Following are possible functions these buttons will act:

Control

- FL/EQU
- HVSD RST
- SMR RST
- Voltage/Current Display

Settings	Description
FL/EQU - Function	- This button is used to manually select SMR into float or equalize state.
HVSD RST - Function	- When SMRs shut down resulting from DC high voltage. This button is used to reset alarm state.
SMR RST - Function	System will detect RFA warning when SMRs are vacant or turned off. However, if the button is pushed at this time, the system will stop sending the warning.
Voltage/Current - Function	This button is used to change the voltage or current of LED display.

Notice: When SMR turn off , the system will detect RFA warning in ES48/90-JFAxx.

When SMR vacant , the system will detect RFA warning in other system.

4.2.3 Indicators

Table 15 displays the ALU indicators.

Table 15 ALU Indicators

Indicator	Color	Function	Description
LED1	Green	FL	System Float State
LED2	Yellow	EQU	System Equalize State
LED3	Red	HV	DC High Voltage Alarm-Minor
LED4	Red	LV	DC Low Voltage Alarm-Minor
LED5	Yellow	MIN	System Minor Alarm
LED6	Red	MAJ	System Major Alarm
LED7	Red	HVSD	High Voltage Shutdown (DC)
LED8	Red	AC FAIL	Loss of AC Input
LED9	Red	FUSE ALM	DC Output or Breaker SW. Trip
LED10	Red	LVDS OPEN	Low Voltage Disconnect Open

4.2.4 Relay Output

Table 16 displays the relay output.(Please refer to Figure 5)

Table 16 Relay Output

Relay	Function	Description	Relay	Function	Description
Relay1	ACF	AC Failure	Relay5	LV	DC Low Voltage Alarm-Minor
Relay2	MAJ	Major Alarm	Relay6	LVD	Low Voltage Disconnect Open
Relay3	HVSD	High Voltage Shutdown	Relay7	FA	Breaker Trip Alarm
Relay4	HV	DC High Voltage Alarm-Minor	Relay8	MIN	Minor Alarm

4.2.5 ALU Alarm Signal Descriptions

MAJ: Major Alarm

- (1) 2 or above rectifiers fail.
- (2) Temperature sensor disconnects.
- (3) AC Low Voltage Alarm.
- (4) AC High Voltage Alarm.
- (5) LVDS Trip Alarm. (System equipped with PDU)
- (6) Battery or Ambient over temperature. (System equipped with PDU)
- (7) HVSD Alarm.
- (8) Breaker Trip Alarm.

MIN: Minor Alarm

- (1) One rectifier fail.
- (2) Current Limit Alarm.
- (3) DC High Voltage Alarm.
- (4) DC Low Voltage Alarm.

HV: The alarm condition exists when the DC output voltage is higher than the parameter setting.

LV: The alarm condition exists when the DC output voltage is lower than the parameter setting.

AC Fail: The alarm condition exists when the AC voltage is absent.

LVDS: The alarm condition exists when the DC output voltage is lower than the threshold voltage. (System equipped with PDU)

Fuse Fail: The alarm condition exists when the battery switch trip off or the DC Load output switch trip off.

4.2.6 Physical

Table 18 displays the ALU mechanical data.

Table 18 ALU Mechanical Data

Dimension	Value
Height	5.2 in. (132mm)
Depth	9.9 in. (251.3mm)
Width	1.9 in. (46.2mm)

4.2.7 Environmental

Table 19 displays the environmental specifications.

Table 19 Environmental Specifications

Specification	Value
Operating temperature	32°F to +122°F (0°C to +50°C)
Storage temperature	-40°F to +185°F (-40°C to +85°C)
Humidity	0% to 95% Relative Humidity No condensing
Altitude	-500 to 10,000 ft.
Weight	2.64 lbs. (1.2Kg)
ESD	IEC 1000-4-2 (Contact 4KV Air 8KV)

4.2.8 Remote monitoring and control

The ALU provide the following remote monitoring methods.

1. Use RS232 Interface.
2. Use Internet Web server function (RJ45)-(Optional)

4.2.10 Parameter Modify

Enter the Remote monitoring software or use the internet Brower to modify the parameter.

4.3 Alarm Control Unit Block Diagram

Refer to Figure 7.

4.4. Settings and Control

Settings:

Settings	Description	Comment
DC High Voltage Shutdown		
Function	- High voltage shutdown threshold adjustment	
Default	- 58.5VDC (-48V System) - 29.5VDC (+24V System)	
Recovery	- 57.5VDC (-48V System) - 28.5VDC (+24V System)	
Steps	- 0.1VDC	
DC High Voltage Alarm		
Function	- High voltage alarm threshold adjustment	
Default	- 57.5VDC (-48V System) - 29VDC (+24V System)	
Recovery	- 56.5VDC (-48V System) - 28VDC (+24V System)	
Steps	- 0.1VDC	
DC Low Voltage Alarm		
Function	- Low voltage alarm threshold adjustment	
Default	- 44.0VDC (-48V System) - 23VDC (+24V System)	
Recovery	- 45.0VDC (-48V System) - 24VDC (+24V System)	



Settings	Description	Comment
Steps	- 0.1VDC	
AC High Voltage Alarm		
Function	- AC high voltage alarm threshold adjustment	
Default	- 264V	
Recovery	- 261V	
Steps	- 1V	
AC Low Voltage Alarm		
Function	- AC Low voltage alarm threshold adjustment	
Default	- 176V	
Recovery	- 179V	
Steps	- 1V	
Temperature Alarm		
Function	- Battery Temperature alarm	
Default	- 104°F (40°C)	
Steps	- 1°C	
Site ID		
Function	- Set identification number for this site	
Setting	- 4 digits and number range is 0-9	
Floating / Equalize charging voltage		
Function	- Float / Equalize charging voltage	
Default	- Float - 54.3VDC (-48V System) - 27.2VDC (+24V System) - EQUALIZE - 56.4VDC (-48V System) - 28.2VDC (+24V System)	
Steps	- 0.1V	
LVDS Trip Voltage		
Function	- Sets LVDS trip voltage	
Default	- 42VDC (-48V System) - 22VDC (+24V System)	
Recovery	- When one rectifier work normally and not in the CL Mode	
Steps	- 0.1V	
Compensation On/Off		
Function	- Enable / Disable Temperature Compensation feature	
Setting	- ON/OFF	
Default	- On	
Compensation Volt. Range		
Function	- To set Temperature Compensation Voltage	
Default	- -1.3VDC~+1.3VDC (-48V System) - -0.7VDC~+0.7VDC (+24V System)	
Steps	- 0.1V	
Equalize Duration Time		
Function	- To set the duration of equalizes charging after AC recovery. This setting is active when battery deeply discharge resulting from AC fail.	
Default	- 1-10 hours	
Steps	- 1 hour	
Mains Recovery Charging Current Limited		
	- When mains recovery to avoid the charging current too large, CSU will limit the charging current.	
	- [(IL+ Max. Cap.) / Parameter] / available SMR	

Settings	Description	Comment
Function		
Battery Max. Capacity		
Default	- 74AH	
Range	- 1~2500 AH	
Parameter		
Default	- 4	
Range	- 1~20	
Temperature Shut Down		
Function	- High Temperature Shutdown	
Default	- 149°F	
Recovery	- 122°F	

Control:

Settings	Description	Comment
Remote SMR On/Off		
- Function	- Remote SMR on/off capability exists through the CSU control.	SMR Shutdown (1-3)
- Description	- CSU automatically shuts down SMR in case of DC high voltage. - Users can manually shut down SMR from Remote Management System.	
Floating / Equalize control		
- Function	- SMR floating/equalize status can be set through the CSU control.	
- Description	- CSU automatically transfer SMR to floating mode in case of mains recover after deep discharge resulted from blackout/battery test - Users can manually set SMR to floating or equalize from CSU.	
HVSD Recovery		
- Function	- When system HVSD alarm recovery and system voltage reduce to normal, this function is used to reset the HVSD alarm	

5 DC Distribution

5.1 DC Cabling

You can find DC output which marked Load + and Load – behind the shelf of the left hand side.

5.2 Low Voltage Battery Disconnect (System equipped with PDU)

The low voltage disconnect contactor is installed in front of the battery connection bus. Battery and system bus are connected in parallel. When LVDS opens, it disconnects the batteries from the system bus.

5.3 Battery Connections (System equipped with PDU)

The battery connections which are behind the distribution module should be made through the breaker. BAT + for battery positive and BAT – for battery negative.

5.4 Battery Temperature Probe Connection (System equipped with PDU)

The battery temperature probe senses the battery temperature and sends the signal back to the ALU. The temperature is used to determine the temperature compensation voltage. A temperature sensor is included with each Power Shelf. To connect the temperature sensor, perform the following steps:

1. Connect the sensor to the connector labeled TB located behind the shelf.
2. Attach the copper lug sensor to the center position.

6 Installation

6.1 Preliminary Inspection

Prior to removing the system from the crate, note any damage to the carton. Remove the system from the packaging and inspect the shelf and components for any dents or damage. If any damage is noted, contact the carrier immediately.

6.2 System Mounting

The power system is typically shipped with the shelf in one carton and rectifiers in individual cartons. The shelf typically is shipped with the ALU and the distribution module. The module can be mounted in a 19" relay rack provided by the customer.

This system allows the relay rack to be installed as close to a rear wall as is necessary for the installation. The front of the system should be clear of all obstruction and allow room for proper ventilation, installation, and maintenance.

6.3 Module Installation

In order to reduce the weight of the system, all power modules can be removed from the shelf when mounting the shelf onto a rack.

- 1) Ensure that the AC power is isolation.
- 2) Loosen the fixed thumbscrew on the rectifier and pull the rectifier out.
- 3) Loosen the fixed thumbscrew on the ALU panel and pull the ALU out.
- 4) Reverse the procedure, to install the rectifier and ALU.

6.4 Shelf Wiring

The shelf comes fully assembled and is equipped with the ALU and the distribution module. All internal connections are made at the factory. No internal, shelf, or module wiring is required.

6.5 AC Input Connections

The power system is equipped with one power terminal located at the center rear of the shelf.

- Warning:**
1. *AC power wire cannot less than AWG 10 and failure to use the appropriate power wire causes safety hazards.*
 2. *Each shelf requires a properly grounded AC input feeds supplied by Delta.*
 3. *The system operates at AC voltages that can produce fatal electrical shock. Installation and maintenance personnel must observe all safety precautions.*
 4. *Confirm the operating voltage and proper grounding of the incoming line before proceeding.*

6.6 Battery String Connections (System equipped with PDU)

- Warning:**
1. *Verify the polarity of the battery leads prior to connecting the battery cables to the system. Failure to connect the battery cables correctly to the system can cause damage to batteries and the system.*

2. *While connecting the battery cables inside the distribution module, make sure the system is completely disenergized (that is, the AC lines are turned off and the battery cables are disconnected at the battery end).*
3. *The system voltage (rectifier output voltage) is -48VDC. Connect the positive battery cable(s) to the BATT + and connect the negative battery cable(s) to the BATT -.*

6.7 Temperature and Alarm Connections

6.7.1 Battery Temperature Sensors

One (1) battery sensor cable is provided with each system. The connection method please refers to section 5.4.

6.7.2 External Alarm Connections

1. Table 21 Alarm Terminal Block Pin Assignments

Alarm	Description
ACF	AC Fail
MAJ	Major
HVSD	High Voltage Shutdown
HV	High Voltage Alarm
LV	Low Voltage Alarm
LVD	Low Voltage Disconnect
FA	Fuse Alarm
MIN	Minor

2. Each alarm connection is provided with a normally close relay contact. This contact is capable of carrying 0.5 Amp DC at 30VDC on a continuous basis.
3. **Warning:** *All external circuits connected to these alarm relay terminals must be secondary and properly isolated from the incoming line.*

6.8 Connect the PDU signal cables to the rear of the shelf which are mark “EXT. Breaker trip signal I/P” connector.

The “FUSE ALM” LED on the front panel of ALU will light up when the breaker open.

6.9 AC High Voltage Aux. Relay output wiring

The connection point of “AC High Voltage Trigger Relay” which is on the rear of shelf will close when the AC input voltage is higher than the setting value normally it’s open.

7 System Start-Up Procedure

7.1 Initial Start-Up Preparation

1. Verify all connections prior to starting this section.
2. Confirm the operating voltage before proceeding.
3. Ensure that the AC line is properly grounded.
4. Ensure the battery DC circuit breaker is switched to the “OFF” position
5. Ensure the PSU breaker is switched to the “OFF” position.

7.2 No Load Start-Up

The system can be started up without a load. To start up the system, perform the following steps:

1. Switch all DC distribution circuit breakers to the “OFF” position and/or remove all the fuses. If there is the PDU in the system.
2. Verify that the battery is not connected to the system battery bus or ensure the battery switch in the “OFF” position.
3. Check the ALU for alarm and status conditions.

7.3 Basic Functional Verification

After system start-up, basic functional verification should proceed as follows:

1. Check the ALU status and alarm LEDs.
2. Compare the rectifier DC voltage readings at the ALU with the output voltage of each rectifier by using digital multimeter (measure at the V+ and V- points located on the front of each rectifier).
3. The “FUSE ALM” LED on the panel light because the battery breaker is switched to “OFF”.

7.4 DC Load Connections

1. Connect the positive load wires to the Load +.
2. Connect the negative load cable to the Load -.

Please refer to section 5 DC Distribution.

7.5 System Functionality Check

Control and supervisory functional testing can be performed at the ALU after the basic functional testing is completed and the DC load is connected.

7.5.1 System Status and Alarms

Check the status of the equipment by viewing the ALU alarm and status LEDs.

7.6 System Operation

Upon completion of the system functional testing, the system is operational.

8 System Alarms and Troubleshooting

8.1 AC Fail Voltage Alarm Description

8.1.1 Description

If the ALU detects an input AC voltage below 50 VAC, the ALU sends an AC Fail alarm signal and activates the dry contact. The AC Fail LED on the ALU panel lights up. When AC voltage is restored to the nominal input voltage, the ALU extinguishes the AC Fail LED, and returns the contact to the normally closed position.

8.1.2 Troubleshooting

The AC Fail alarm is normally caused by a commercial AC interruption due to a storm or maintenance. If commercial AC is detected at the AC panel, check the rectifier input breakers in the AC panel for a tripped or failed breaker.

Warning: *The ALU senses the AC line through the AC Input terminal. If this connection is missing, the system generates an AC Fail alarm.*

8.2 High Voltage Shutdown Alarm

8.2.1 Description

When the ALU detects the output DC voltage exceeding the HVSD threshold setting, the ALU sends an HVSD alarm signal and activates the dry contact. The ALU lights the HVSD LED located on the ALU panel and shuts down each rectifier. At this point, the system is running on reserve batteries. When the DC voltage falls below the HVSD threshold voltage, and push the HVSD RST Button, then the system recovers. The ALU extinguishes the HVSD LED, returns the rectifiers to service, and closes the normally closed set of contacts.

8.2.2 Troubleshooting

High voltage shutdown occurs when the output voltage exceeds the HVSD threshold. This can be caused by a rectifier failure, the system equalize voltage exceeding the HVSD threshold, or temperature compensation exceeding the HVSD threshold setting.

1. Restart the rectifiers by resetting the HVSD RST button located on the ALU.
2. Verify the output voltage of each rectifier in both float and equalize.
3. Verify that the equalize voltage setting does not exceed the HVSD threshold setting.
4. Verify the temperature compensation voltage setting. Ensure that Temp Comp does not exceed the HVSD threshold setting when operating in cold temperatures.

8.3 High Voltage Alarm Description

8.3.1 Description

The High Voltage alarm (HV) is a minor alarm activated when the DC output voltage exceeds the HV threshold setting. When the system voltage exceeds the HV setting value, the ALU sends the HV alarm signal, lights the HV LED located on the ALU panel, and activates the HV alarm contact. The rectifiers remain on line during this minor alarm condition. When the system voltage decreases below the threshold setting, the ALU extinguishes the HV LED and deactivates the HV alarm contact.

8.3.2 Troubleshooting

The HV alarm is usually caused when the equalize voltage exceeds the HV threshold setting. Another probable cause is that the temperature compensation voltage exceeds the HV threshold during cold temperature operation. During this alarm condition, the system continues to operate.

8.4 Low Voltage Alarm

8.4.1 Description

The Low Voltage alarm (LV) is a minor alarm activated when the DC output voltage decreases below the LV threshold setting. When the system voltage decreases below the LV LED located on the ALU panel, and activates the LV alarm contact. The rectifiers remain on line during this minor alarm condition. When the system voltage increases above the threshold setting, the ALU extinguishes the LV LED and deactivates the LV alarm contact.

8.4.2 Troubleshooting

The LV alarm condition occurs during a brownout condition or prior to a complete AC Fail condition caused by commercial AC problem conditions.

Another probable cause is that the temperature compensation voltage decreases the float voltage below the LV threshold during hot temperature operation. During this alarm condition, the system continues to operate.

8.5 Low Voltage Disconnect Alarm (System equipped with PDU)

8.5.1 Description

During an AC Fail condition, the rectifiers are shut down and the reserve batteries begin to discharge. When the battery cells discharge below the LVD setting, the ALU lights the LVD LED on the ALU panel, activates the LVDS OPEN alarm contact, and opens the LVDS contactor. When the AC recovers, the LVBD recovers automatically. The ALU extinguishes the LVD LED and resets the normally closed set of alarm contacts.

8.5.2 Troubleshooting

If the battery disconnect switch remains open after voltage is restored to the rectifiers, one of the following is occurring:

1. The ALU may be faulty. Swap out the ALU with a spare and verify voltage settings.
2. The LVBD coil windings may be open. With a digital multimeter, check the LVBD coil windings.

8.6 Fuse/Circuit Breaker Fail Alarm (System equipped with PDU)

8.6.1 Description

If the DC load output fuse opens or battery switch trip off, the ALU sends the alarm condition, lights the LED on the ALU panel, and activates the Fuse Fail alarm.

8.6.2 Troubleshooting

To troubleshoot the fuse/circuit breaker fail alarm condition, perform the following steps:

1. Verify that the fuse/circuit breaker is the proper size (use 80% derating guide).
2. Verify that the external fault that might cause fuse/circuit breaker tripping is removed.
3. Replace the blown fuse with a fuse with the same rating or of the corrected value. In case of a circuit

breaker, turn it on. If necessary replace with the correct size fuse.

If the fuse/circuit breaker continues to trip, perform the following steps:

1. Check the DC branch load to ensure that the fuse/ circuit breaker is the correct size.
2. If the branch load exceeds the fuse/circuit breaker rating, the device must be changed to a higher rating.
3. Install a fuse/circuit breaker with a higher rating.

Warning: *Ensure that the device rating does not exceed the branch load wire capacity. If the device rating is higher than the branch load wire rating, the branch load wire must be changed to a larger wire. Failure to protect the branch load wire may result in overheating and fire.*

8.7 Alarm Unit Fail

8.7.1 Description

During an ALU fail condition, the ALU fail and status LEDs are extinguished, and all alarm contacts open. During an ALU failure, the rectifiers status changes from equalize to float or remains in the float condition. The LVBD does not open during an ALU failure.

8.7.2 Troubleshooting

To troubleshoot the ALU fail condition, perform the following steps:

1. Check the input fuse located on the rear of the ALU. Replace if blown.
2. Check the DC input connectors for proper connections.
3. Replace with a spare and send the faulty unit to Delta for repair.

8.8 Rectifier Fail Alarm

- (1) If one rectifier fails, the MIN contacts open, and the MIN LED on the ALU lights. When two rectifiers fail, the MAJ alarm contact is opened, and the MAJ LED lights.

Warning: *Do not open the rectifier unit. There are no serviceable parts.*

- (2) If you want to ignore the MAJ or MIN alarm when you pull out the rectifiers from the slots, just please press the SMR RST button on the ALU.
- (3) If you insert the above rectifier back to the slot, then pull out after the “FL” LED on the SMR panel light up. The system will alarm in the “MIN” mode.

That means if we repeat to pull out and insert in and pull out the rectifier, the condition described in item (2) will be cleared.

9 Maintenance

9.1 Cleaning and Maintenance

9.1.1 General

Special maintenance is not necessary for this system, unless the system is being operated in a severely harsh environment (dusty environment). The front panels and the cover of the DC distribution cabinet were treated with a special coating. Do not use organic cleanser or volatile solvent because corrosion damage may occur. For periodic cleaning, brush the dust from the cover and panel. If necessary, use a gentle cleanser or a lightly dampened lint free cloth to remove any dirt or smudges.

9.1.2 Periodic Maintenance

Periodic maintenance is not required for normal operation. If necessary, wipe dust from the front of the power system using a lint free, soft cloth and gently wipe the front of the distribution module, the ALU, and the rectifiers. If necessary, use a gentle detergent to clean.

Warning: Do not use a spray cleanser to clean the equipment. Using a spray cleanser directly on the equipment can result in serious equipment damage.

9.2 Removing and Replacing a Rectifier Unit

9.2.1 Removing a Rectifier

Warning: Do not touch the DC output bus when pulling out the PSU module.

To remove a rectifier, perform the following steps.

1. Switch off PSU module.
2. Loosen the captive retaining screws located on the bottom of the front panel.
3. Pull out the rectifier unit slowly from the shelf.

9.2.2 Replacing a Rectifier

To replace a rectifier, perform the following steps:

1. Make sure the breaker on the front panel of PSU is switched off.
2. Install the rectifier unit carefully. Place the rectifier on the shelf, ensuring that the rails are on the track.

Warning: Do not force the module into the slot. If does not slide in and connect easily, remove and reset the unit.

3. Lock the rectifier into position by screwing in the captive retaining screws located at the bottom of the rectifier.
4. Switch on the PSU and check the AC ON LED lights on the front of the PSU on the front of the rectifier. AC ON LED lights.

10 Acronyms and Abbreviations

--- A ---

ALU	Alarm Control Unit
Amp	Ampere
ANSI	American National Standards Institute

--- B ---

BS	British Standard
BTU	British Thermal Unit

--- C ---

C	Centigrade
CB	Circuit Breaker
CE	European Community
CISPR	International Special Committee on Radio Interference
CL	Current Limit
C ^{UL}	Canadian Underwriters Laboratory

--- D ---

--- E ---

EMI	Electro-Magnetic Interference
ESD	Electrostatic Discharge

--- F ---

F	Fahrenheit
FCC	Federal Communications Commission
Ft.	Foot

--- G ---

GND	Ground
-----	--------

--- H ---

HL	High Line
HV	High Voltage
HVSD	High Voltage Shutdown
Hz	Hertz

--- I ---

IEC	International Electronics Commission
IEEE	Institute of Electrical and Electronics Engineers
In.	Inch

--- J ---

--- K ---

Kg.	Kilogram
KHz	Kilohertz



KHz	Kilohertz
KV	Kilovolt
KW	Kilowatt
--- L ---	
Lb.	Pound
LED	Light-Emitting Diode
LL	Low Line
LV	Low Voltage
LVD	Low Voltage Disconnect
LVBD	Low Voltage Battery Disconnect
LVDS	Low Voltage Disconnect Switch
--- M ---	
M	Meter
Max.	Maximum
MHz	Megahertz
Mm	Millimeter
Ms	Millisecond
MTBF	Mean Time Between Failure
MV	Millivolt
mVrms	Millivolt root root mean square
--- N ---	
NEMA	National Electrical Manufacturers Association
No.	Number
--- O ---	
--- P ---	
PF	Power Factor
PFC	Power Factor Correction
PSU	Power Supply Unit
--- Q ---	
Qty.	Quantity
--- R ---	
RFA	Rectifier Failure Alarm
RFI	Radio Frequency Interference
RH	Relative Humidity
RMA	Return Material Authorization
--- S ---	
--- T ---	



TB	Terminal Block
THD	Total Harmonic Distortion
--- U ---	
UL	Underwriters Laboratory
--- V ---	
V	Volt
VAC	Volts AC
VDC	Volts DC
--- W ---	
W	Watt
--- X ---	
--- Y ---	
--- Z ---	

Delta MCS 1800 3U Power Shelf

ATTACHMENT



Figure 1: ES 48/120-JAxx 、 ES 24/200-JAxx (-48V/+24V Power Shelf)

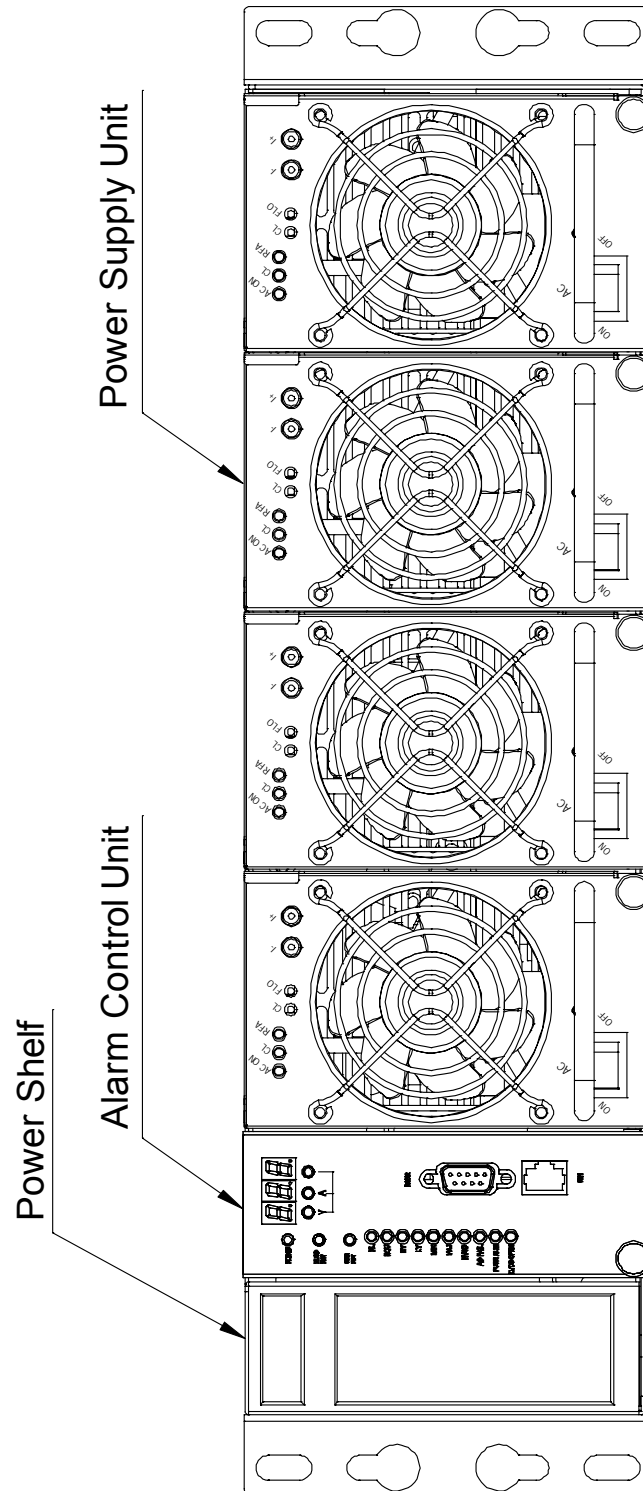

Figure 1-1: ES 48/120-JAAxx 、 ES 24/200-JAAxx (DC Output Lug Distribution)

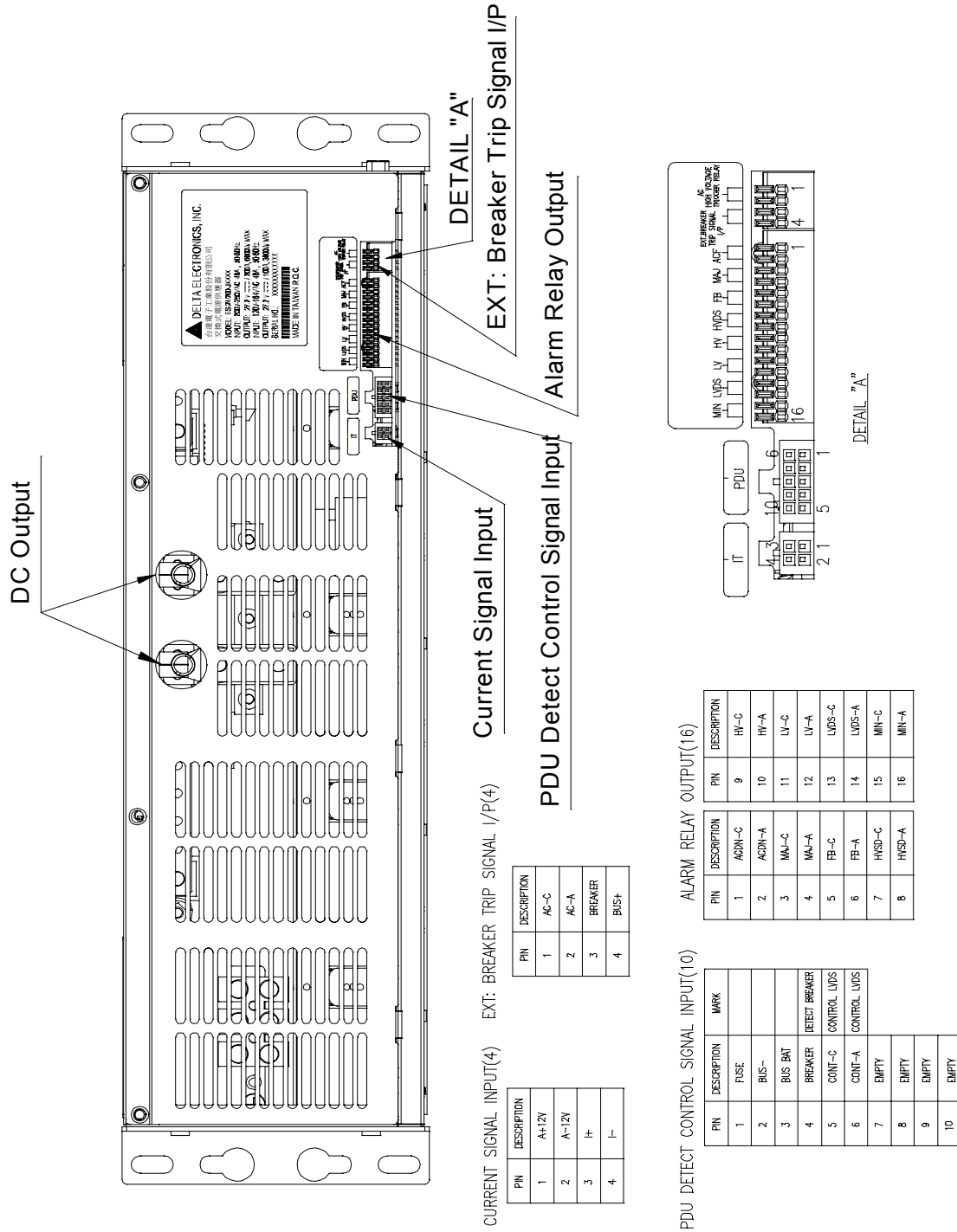
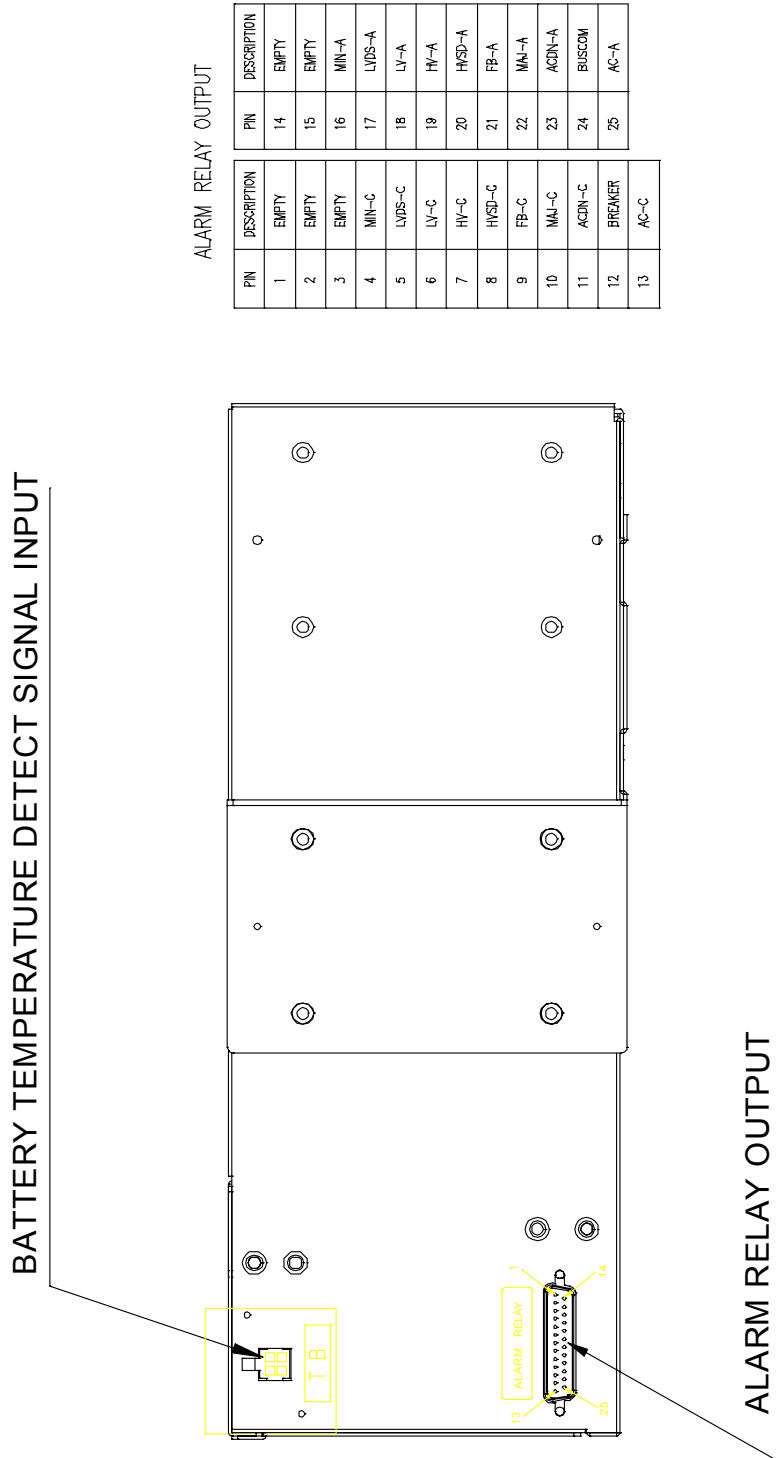

Figure 1-2: ES 48/120-JAAxx 、 ES 24/200-JAAxx (Signal connection Connectors for External Distribution Unit)

Figure 1-3: ES 48/120-JAAxx、ES 24/200-JAAxx (Battery Temperature and Alarm Relay Output Connectors)



ALARM RELAY OUTPUT		ALARM RELAY OUTPUT	
PIN	DESCRIPTION	PIN	DESCRIPTION
1	EMPTY	14	EMPTY
2	EMPTY	15	EMPTY
3	EMPTY	16	MIN-A
4	MIN-C	17	LVDS-A
5	LVDS-C	18	LY-A
6	LY-C	19	HY-A
7	HV-C	20	HVSD-A
8	HVSD-C	21	FB-A
9	FB-C	22	MA-A
10	MA-C	23	ACDN-A
11	ACDN-C	24	BIUSCOM
12	BREAKER	25	AC-A
13	AC-C		

Figure 1-4: ES 48/120-JAAX (Shelf Wiring MCS 1800 Series Shelf)

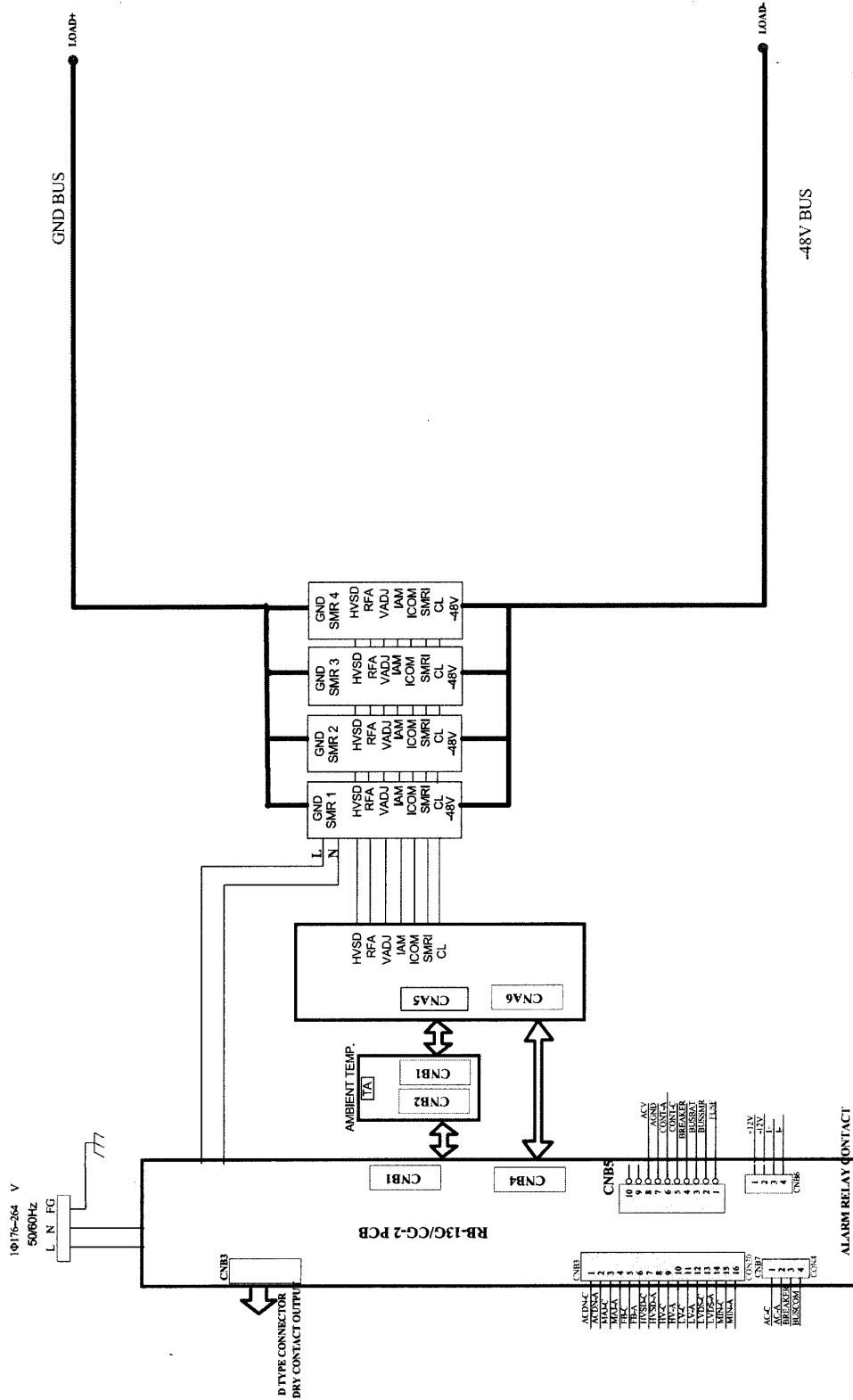

SCHEM ATICS OF MCS 1800 SERIES SYSTEM (-48V)

Figure 1-5: ES 24/200-JAxx (Shelf Wiring Diagram)

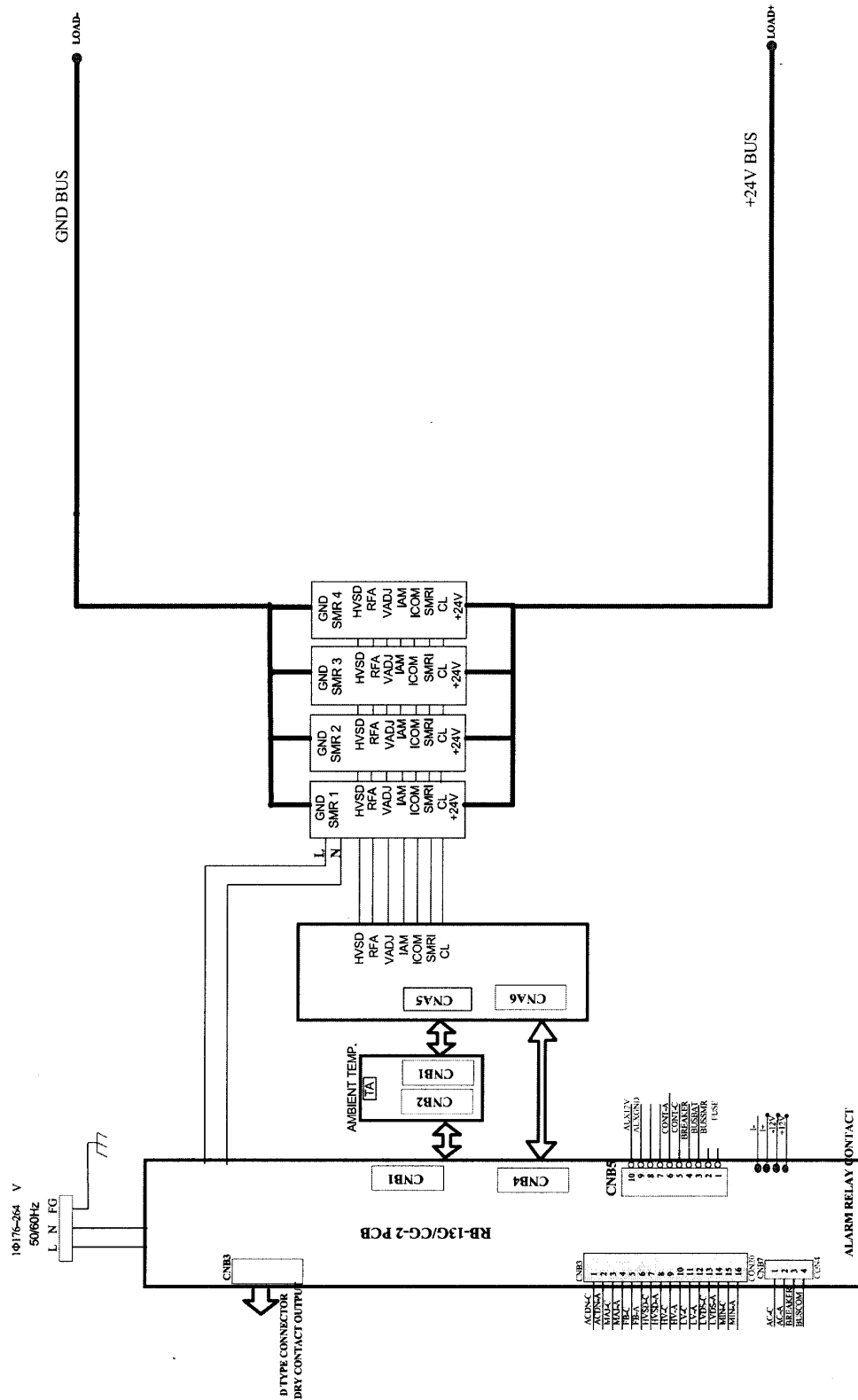

SCHEMATICS OF MCS 1800 SERIES SYSTEM (+24V)

Figure 2: ES 48/90-JBxxx (-48V Power Shelf With PDU)

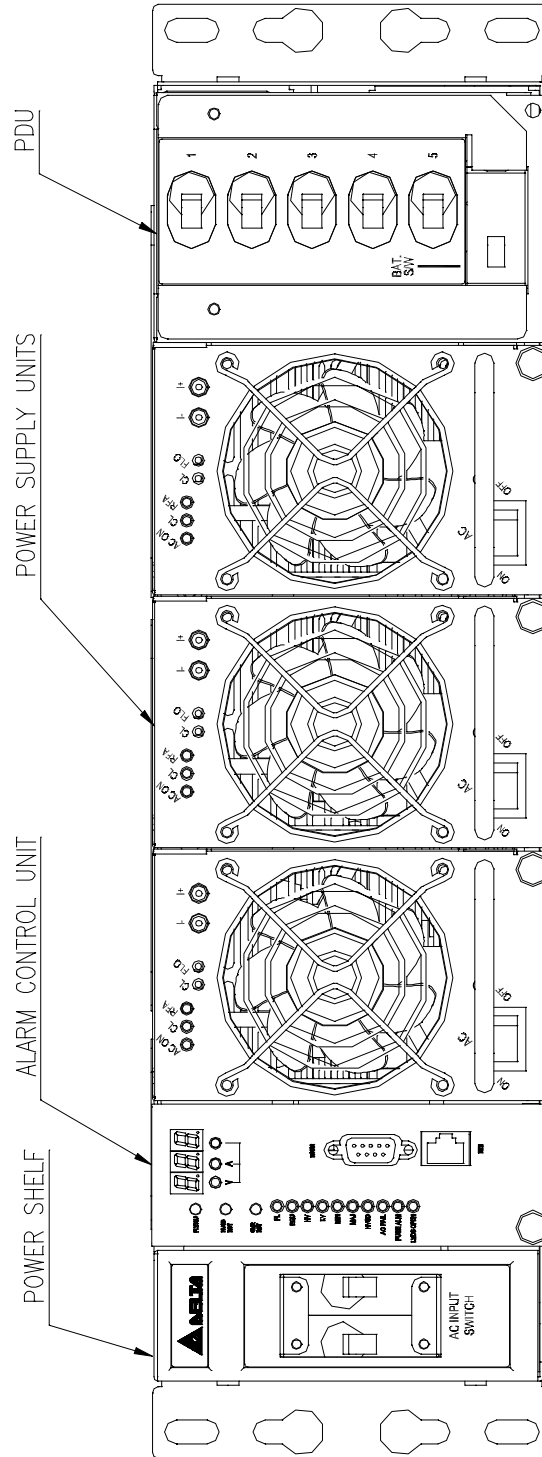
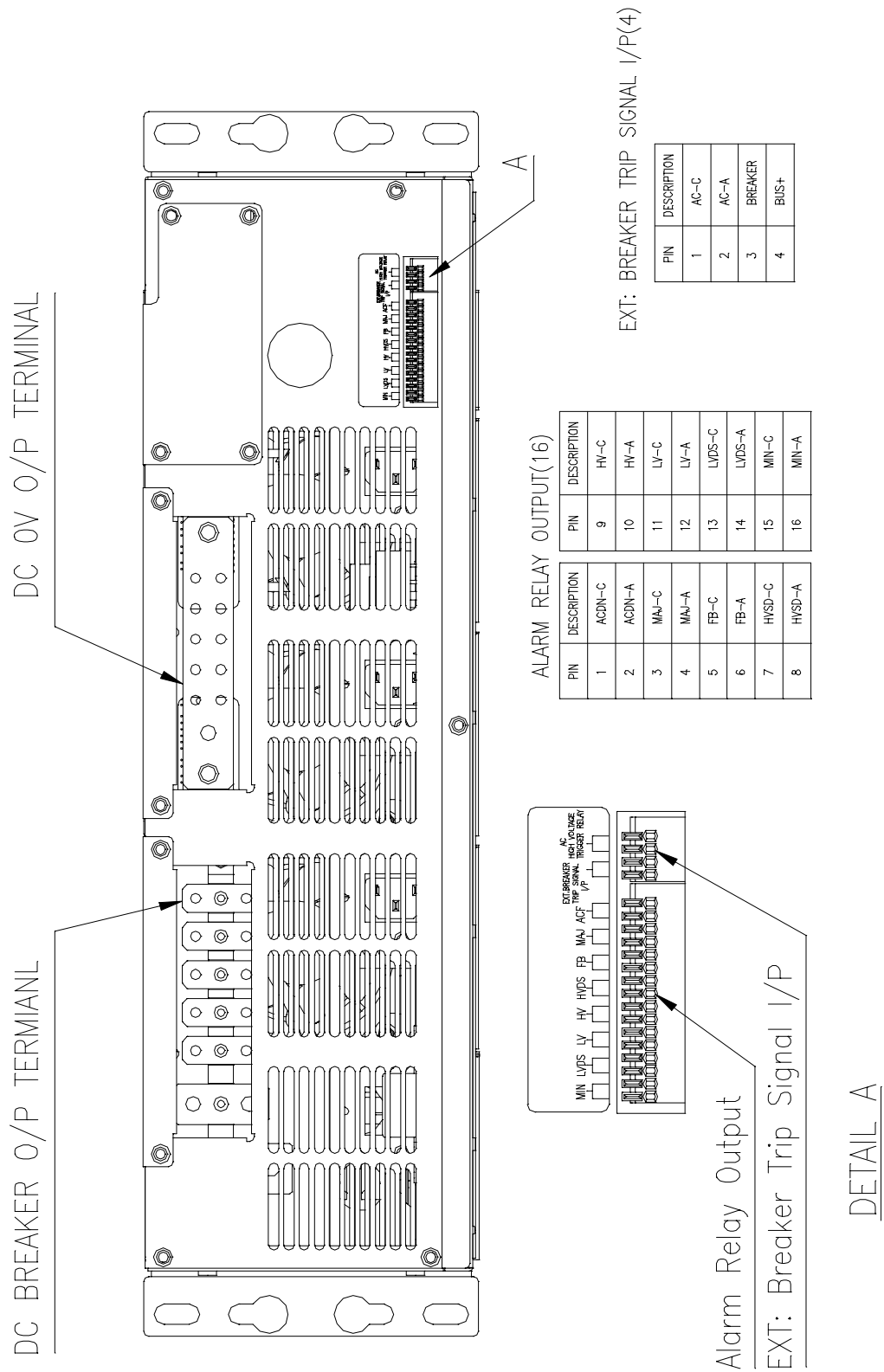

Figure 2-1: ES 48/90-JBxxx (DC Output Lug Distribution)



ALARM RELAY OUTPUT(16)

PIN	DESCRIPTION
1	ACDN-C
2	ACDN-A
3	MAJ-C
4	MAJ-A
5	FB-C
6	FB-A
7	HVSD-C
8	HVSD-A
9	HV-C
10	HV-A
11	LV-C
12	LV-A
13	LVDS-C
14	LVDS-A
15	MIN-C
16	MIN-A

EXT: BREAKER TRIP SIGNAL I/P(4)

PIN	DESCRIPTION
1	AC-C
2	AC-A
3	BREAKER
4	BUS+

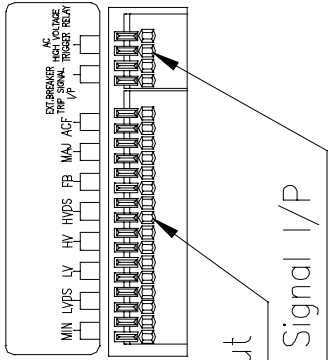

Figure 2-2: ES 48/90-JB Axx (Load Cable and Battery String Connection Terminals)

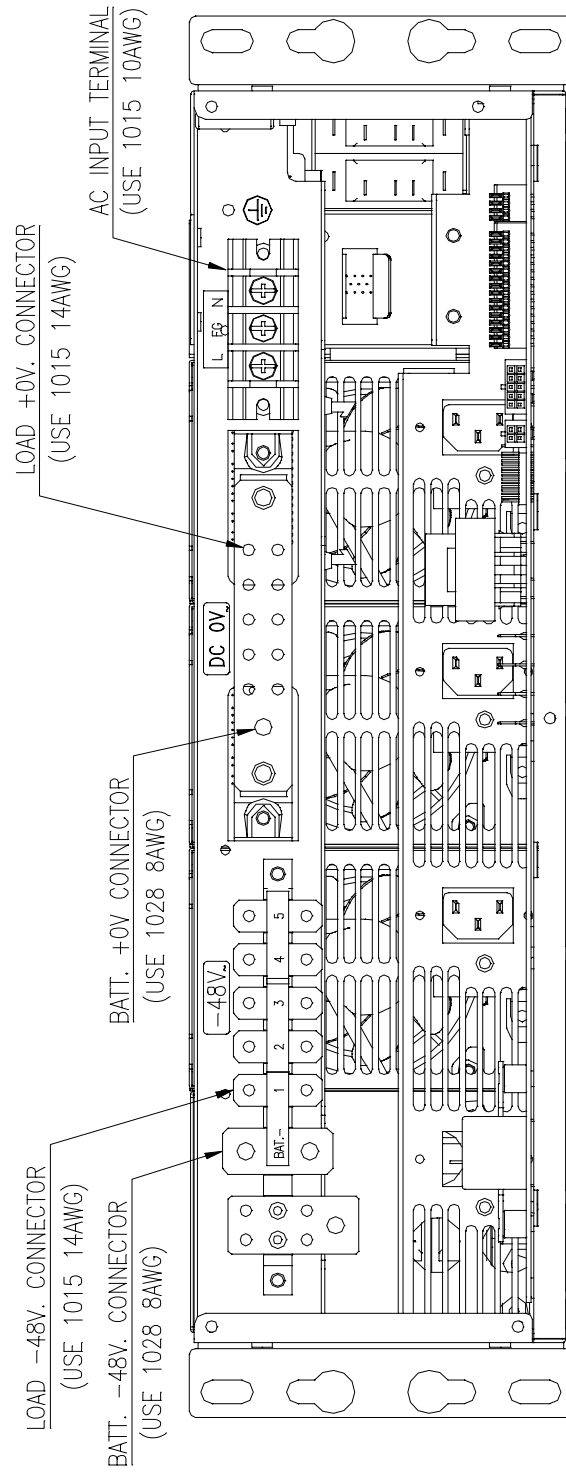

Figure 2-3: ES 48/90-JBAxx (Battery Temperature and Alarm Relay Output Connectors)

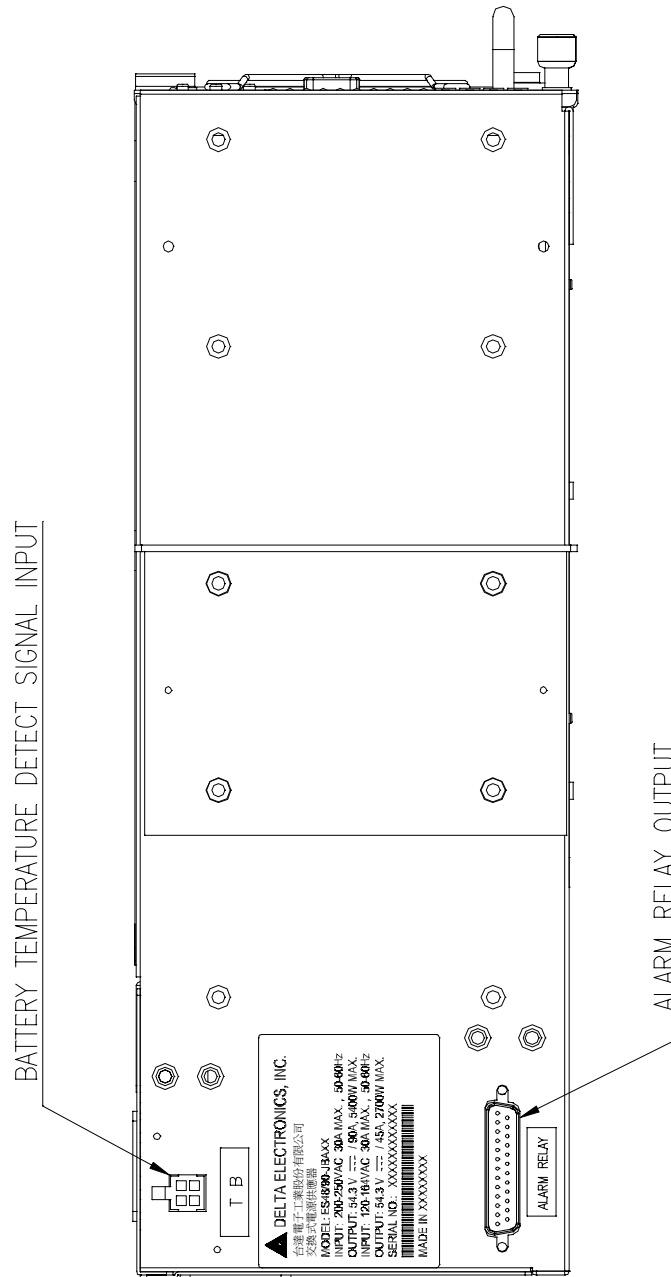

Figure 2-4: ES 48/90-JBAxx (Battery and Load Breaker Distribution)

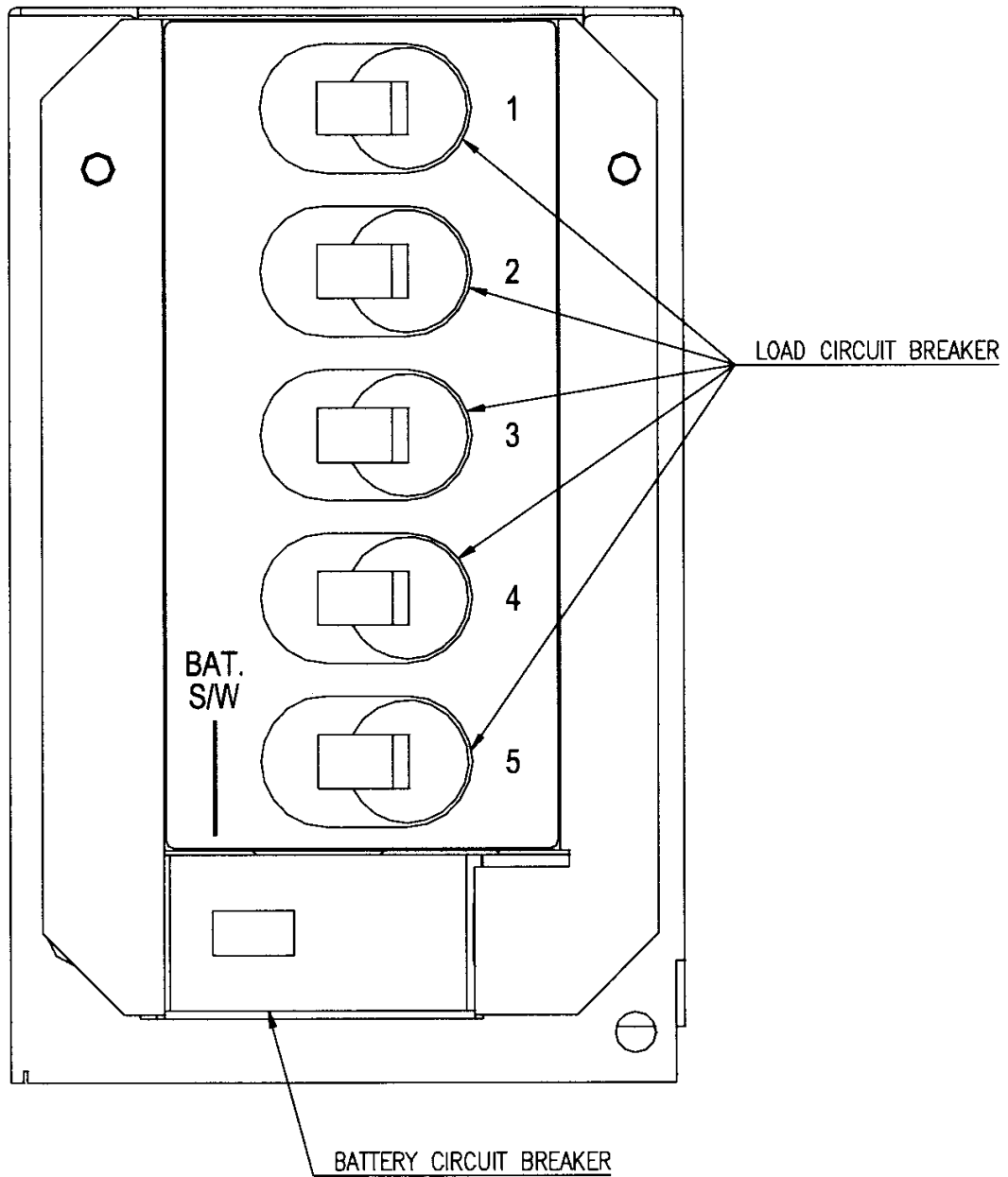
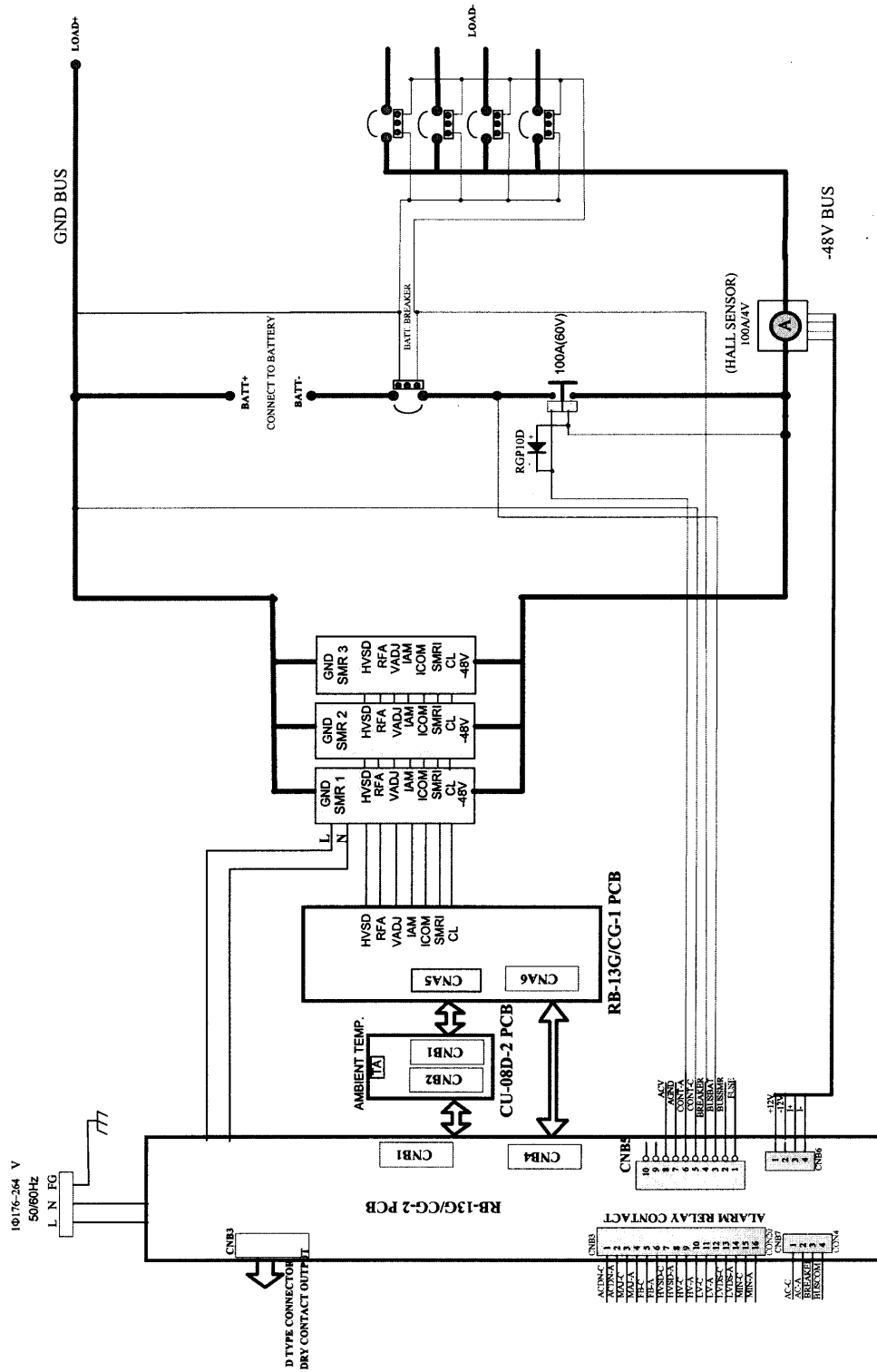

Figure 2-5: ES 48/90-JB Axx (Shelf Wiring MCS 1800 Series Shelf)



SCHEMATICS OF MCS 1800 SERIES SYSTEM (-48V)

Figure 3: ES 48/90-JFAxx (-48V Power Shelf With PDU)

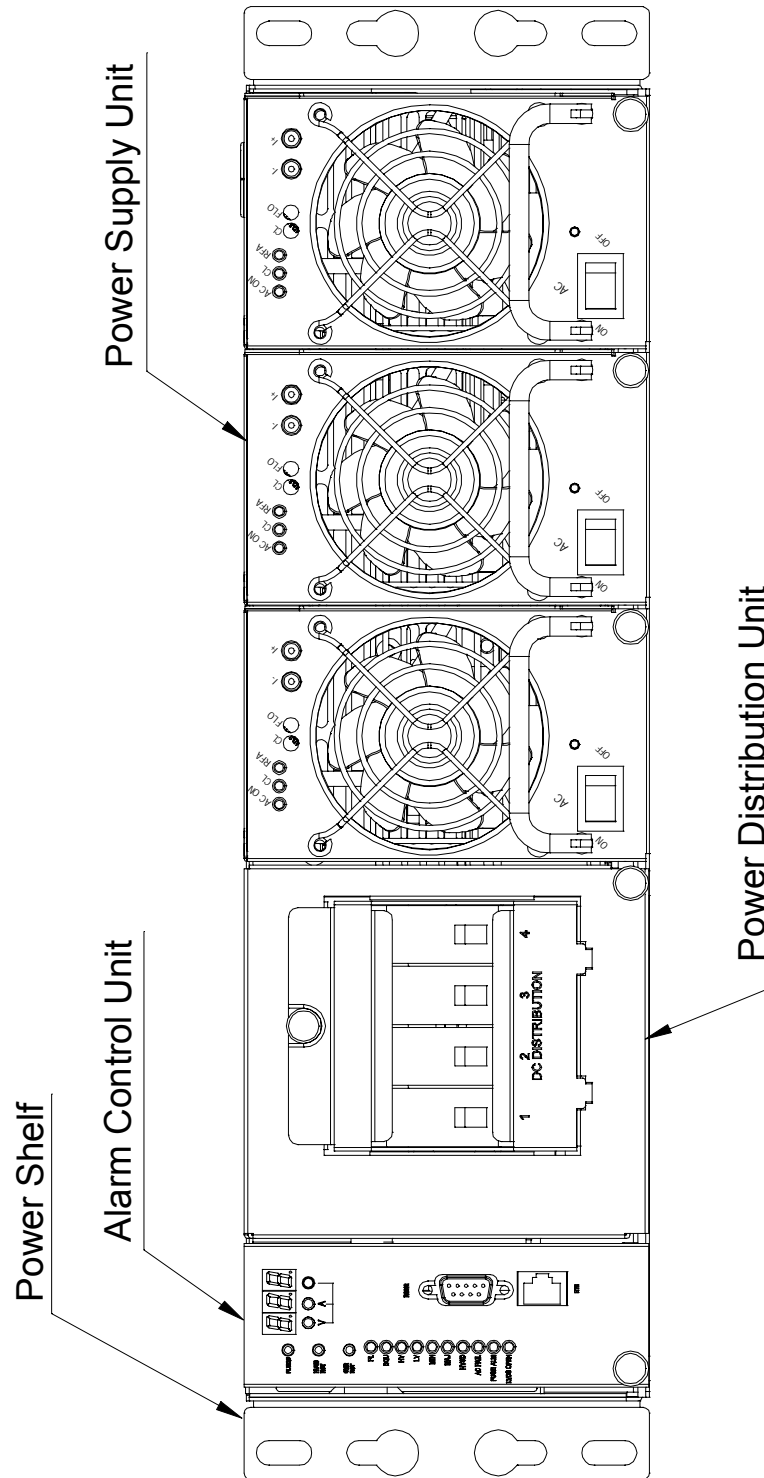

Figure 3-1: ES 48/90-JFAxx (Alarm Relay Output connectors)

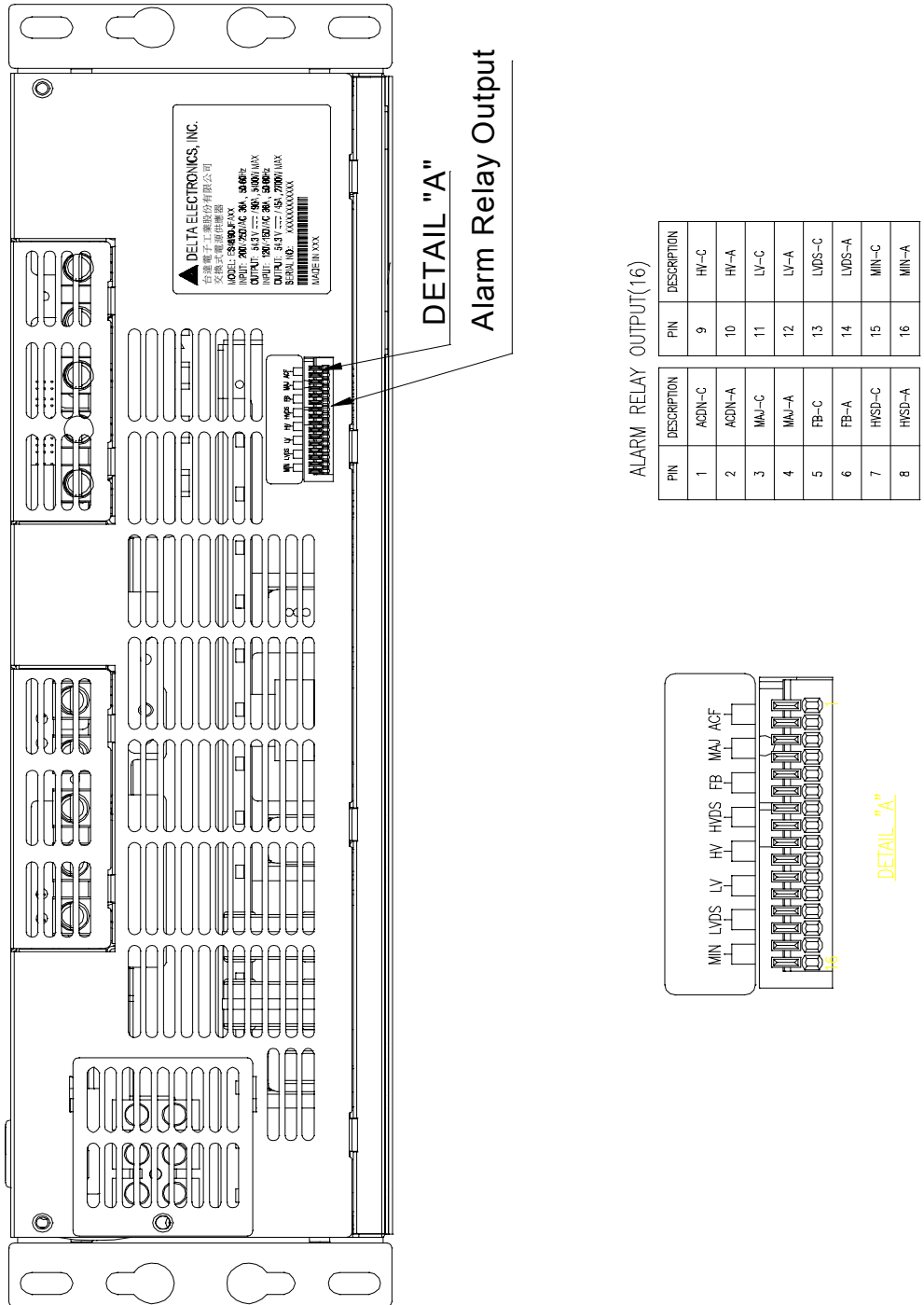

Figure 3-2: ES 48/90-JFAxx (AC Input Connector)

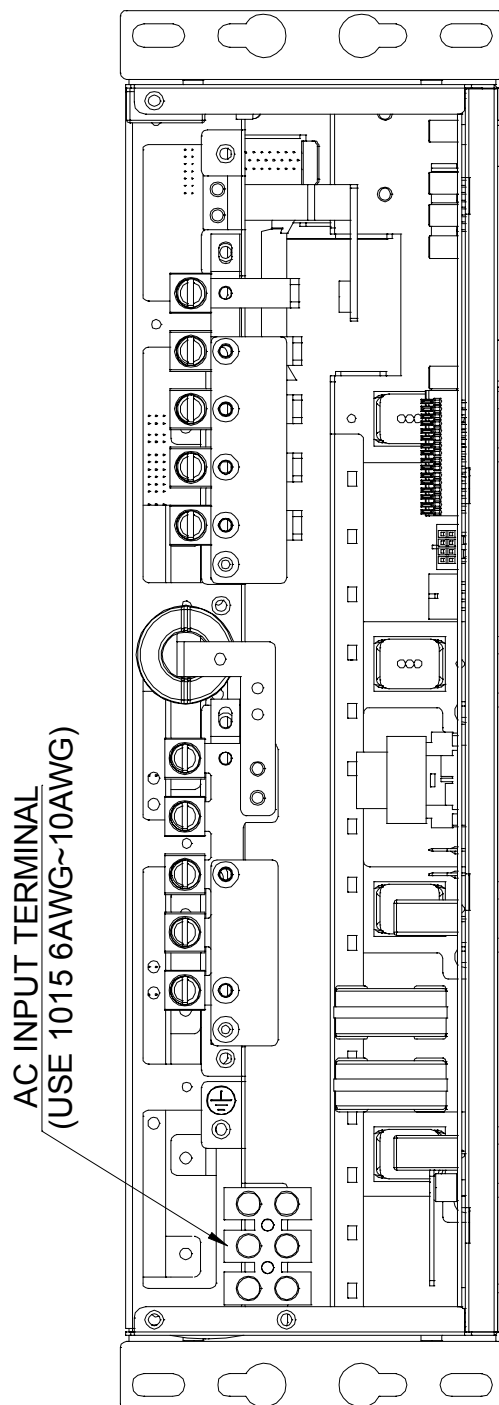

Figure 3-3: ES 48/90-JFAxx (Battery Temperature)

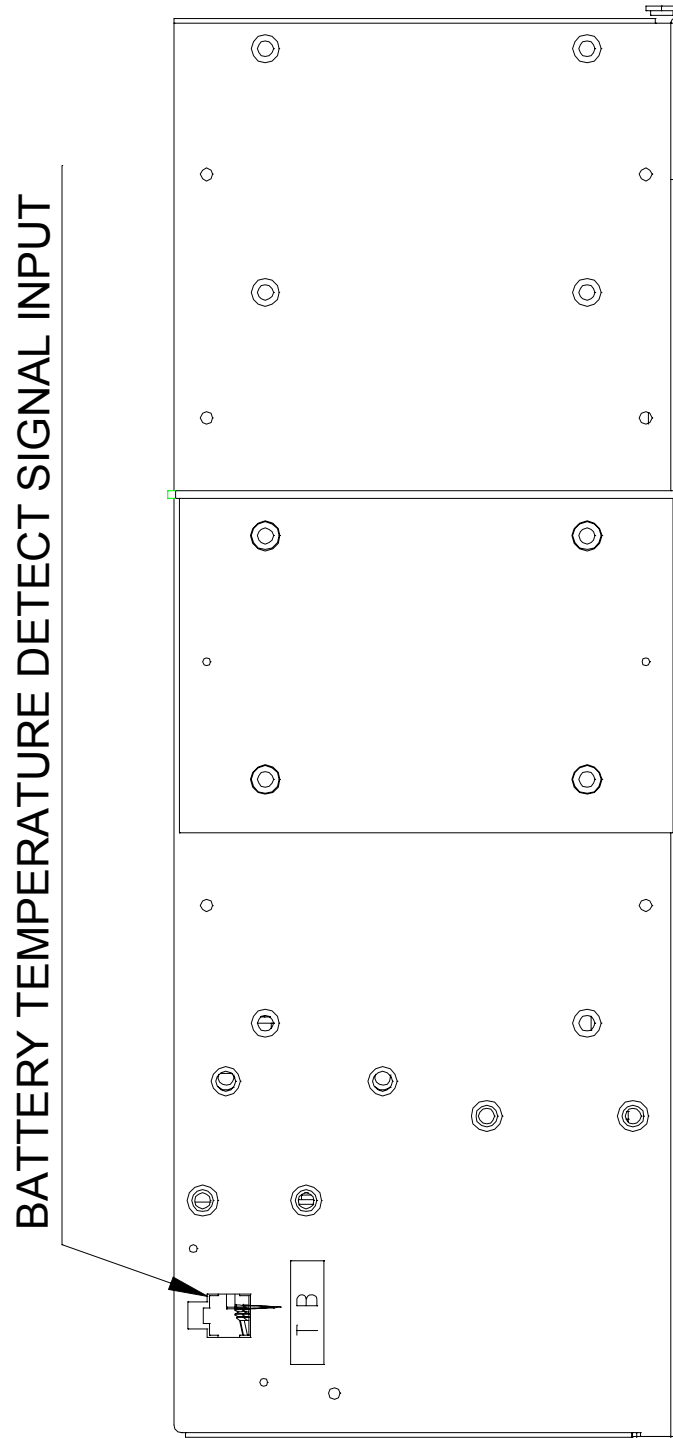

Figure 3-4 ES 48/90-JFAxx (DC Output Lug Distribution)

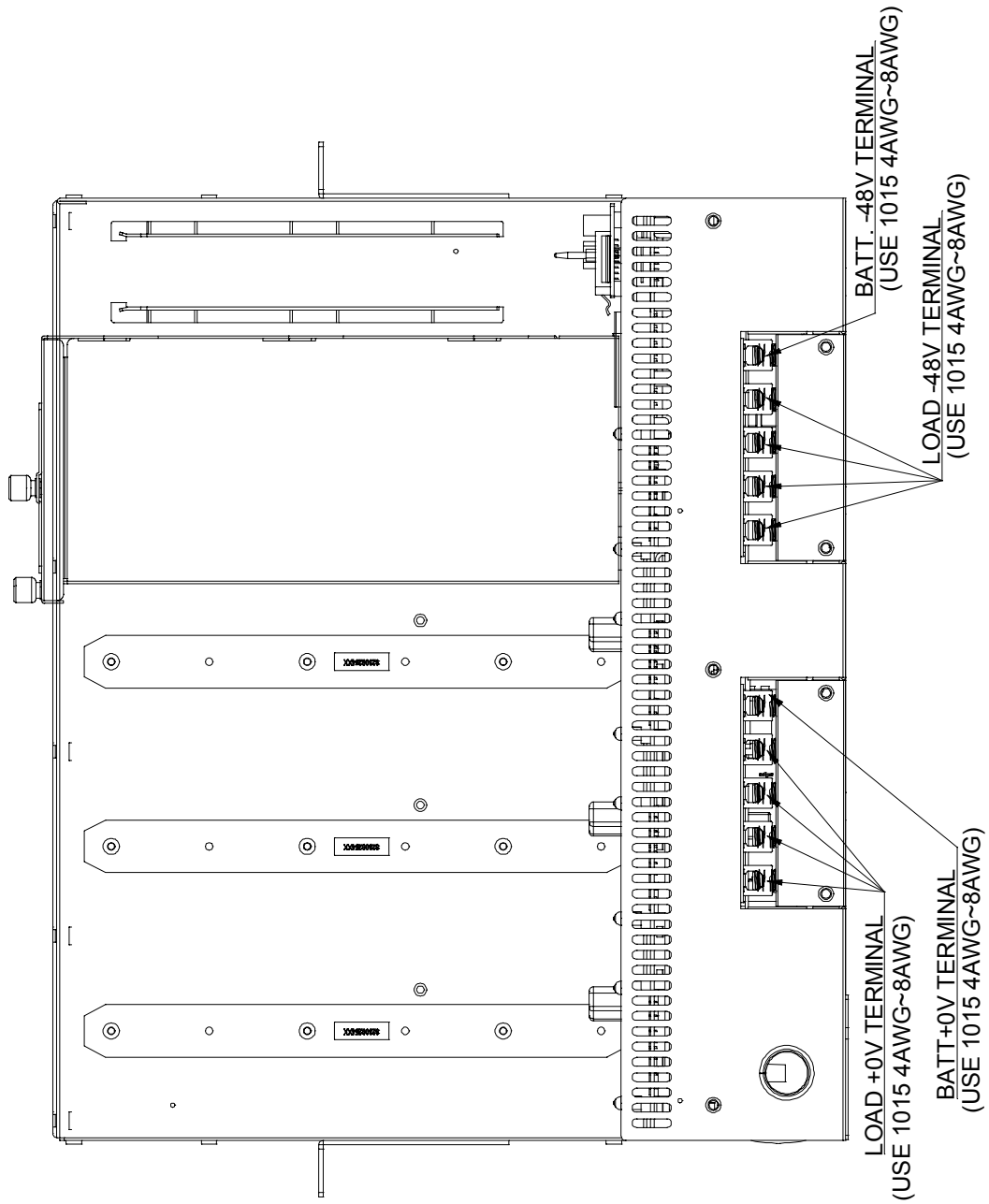
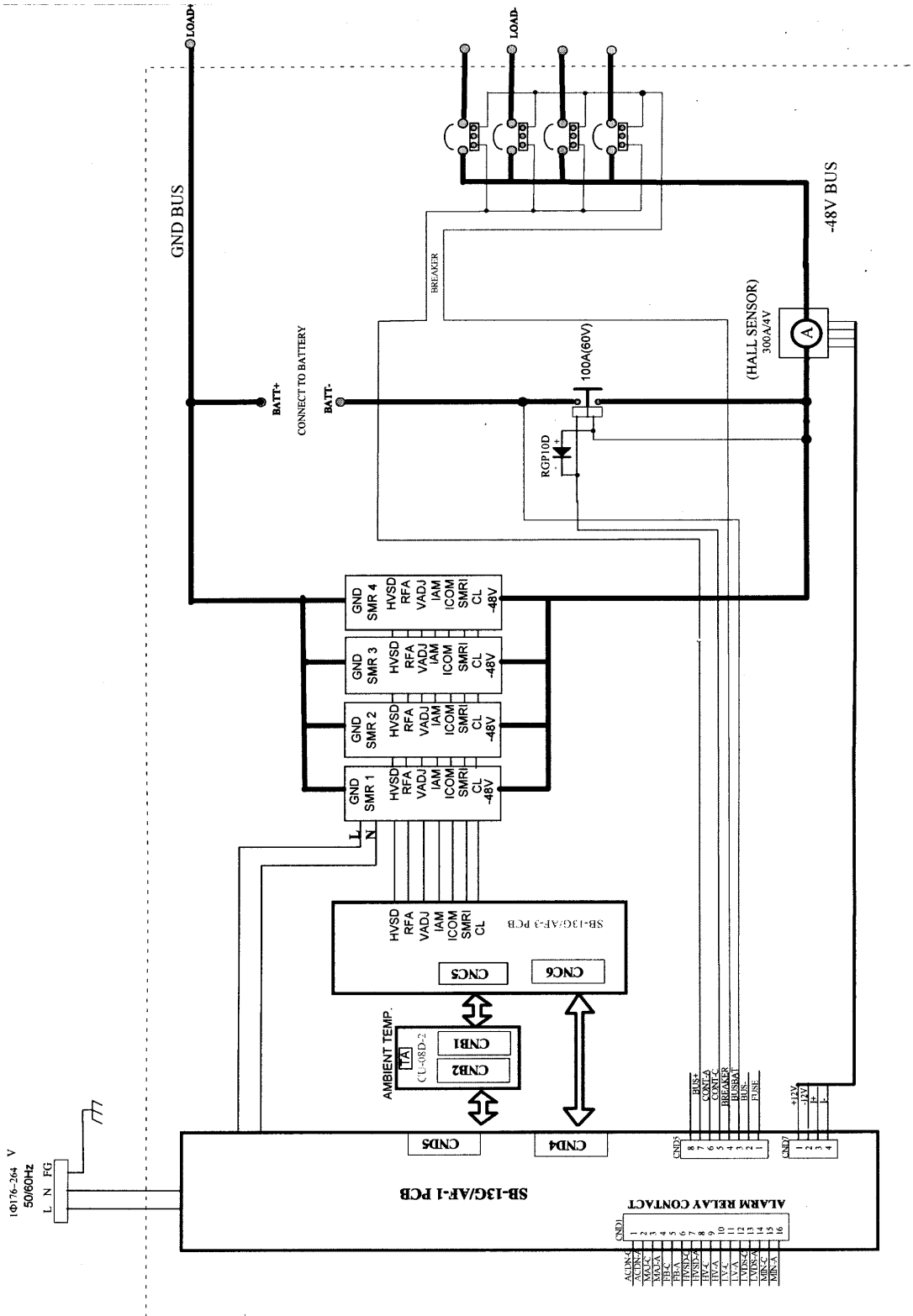

Figure 3-5: ES 48/90-JFAxx (Shelf Wiring MCS 1800 Series Shelf)



SCHEMATICS OF ES48/90-JFAXX (-48V)

Figure 4: Alarm Control Unit

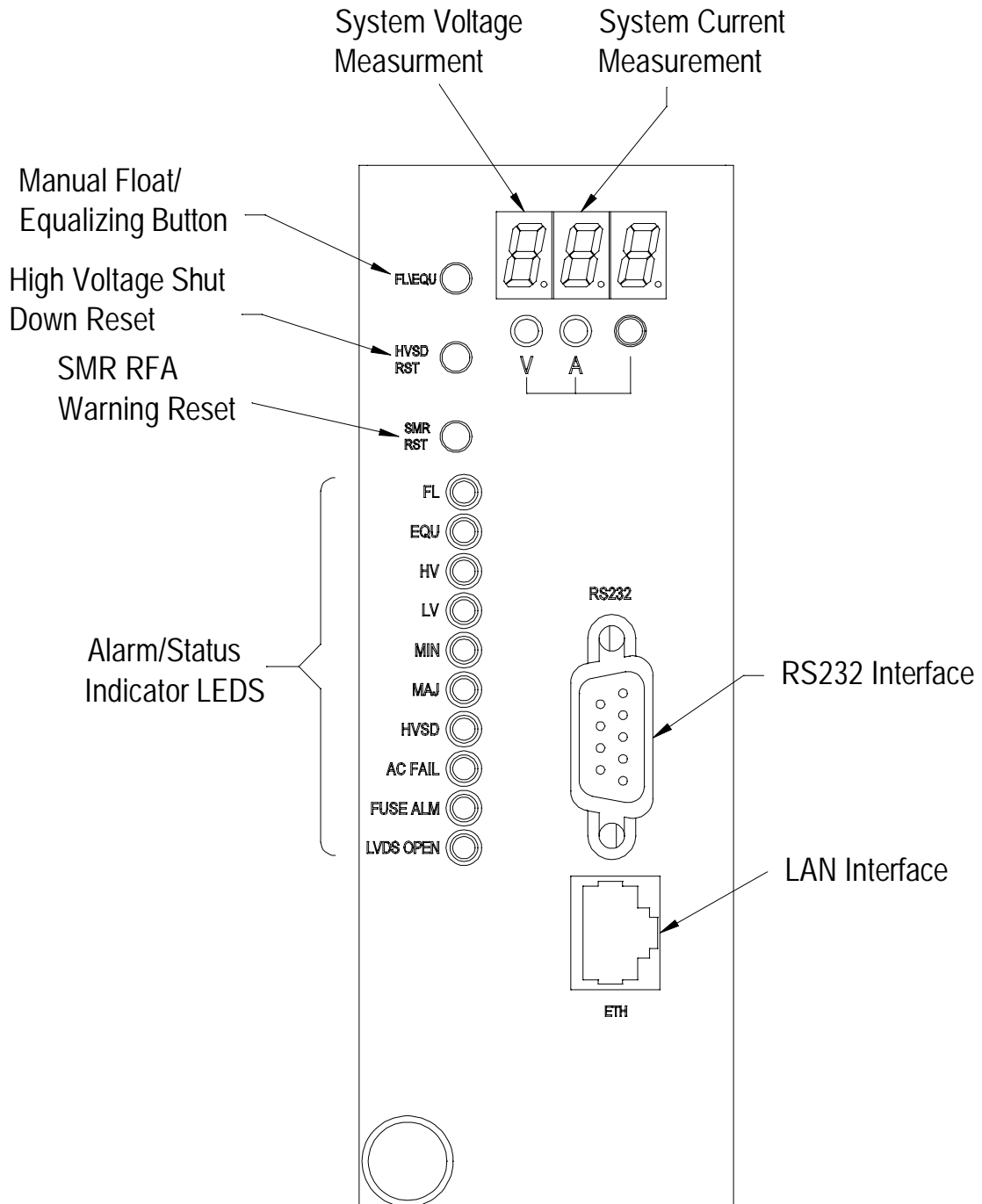

Figure 4-1: Alarm Control Unit

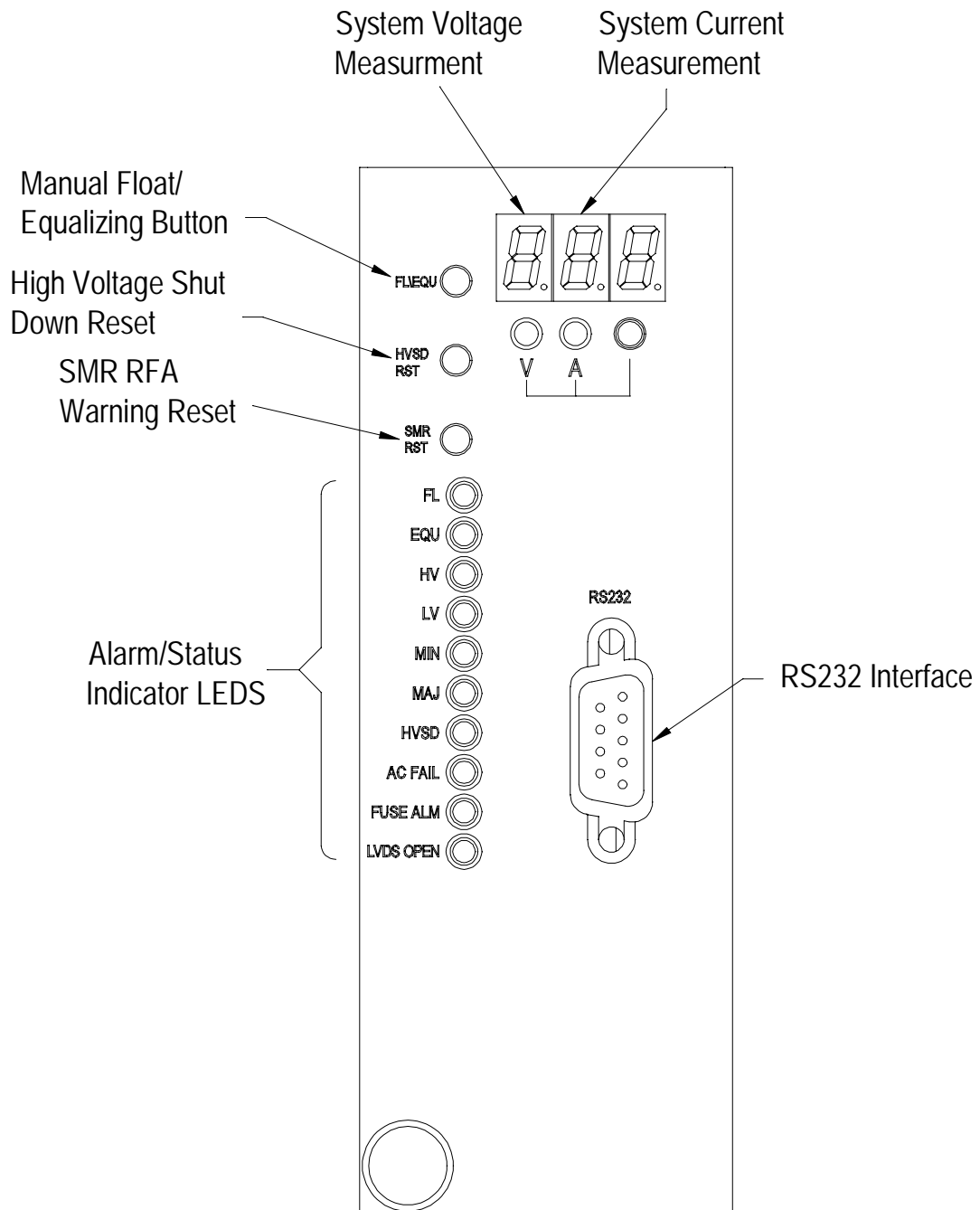

Figure 5: Power Supply Unit

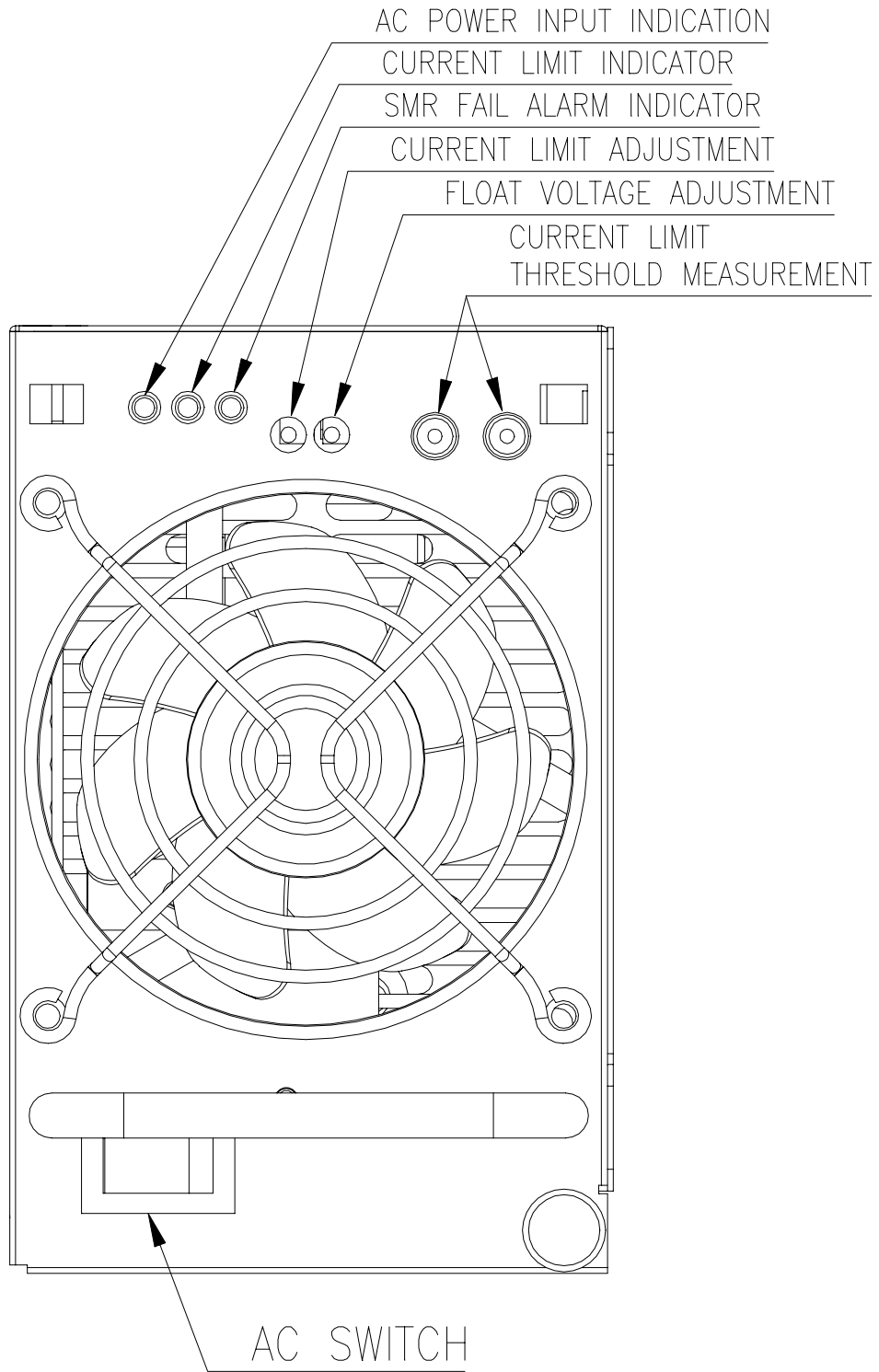

Figure 6: ALU Block Diagram

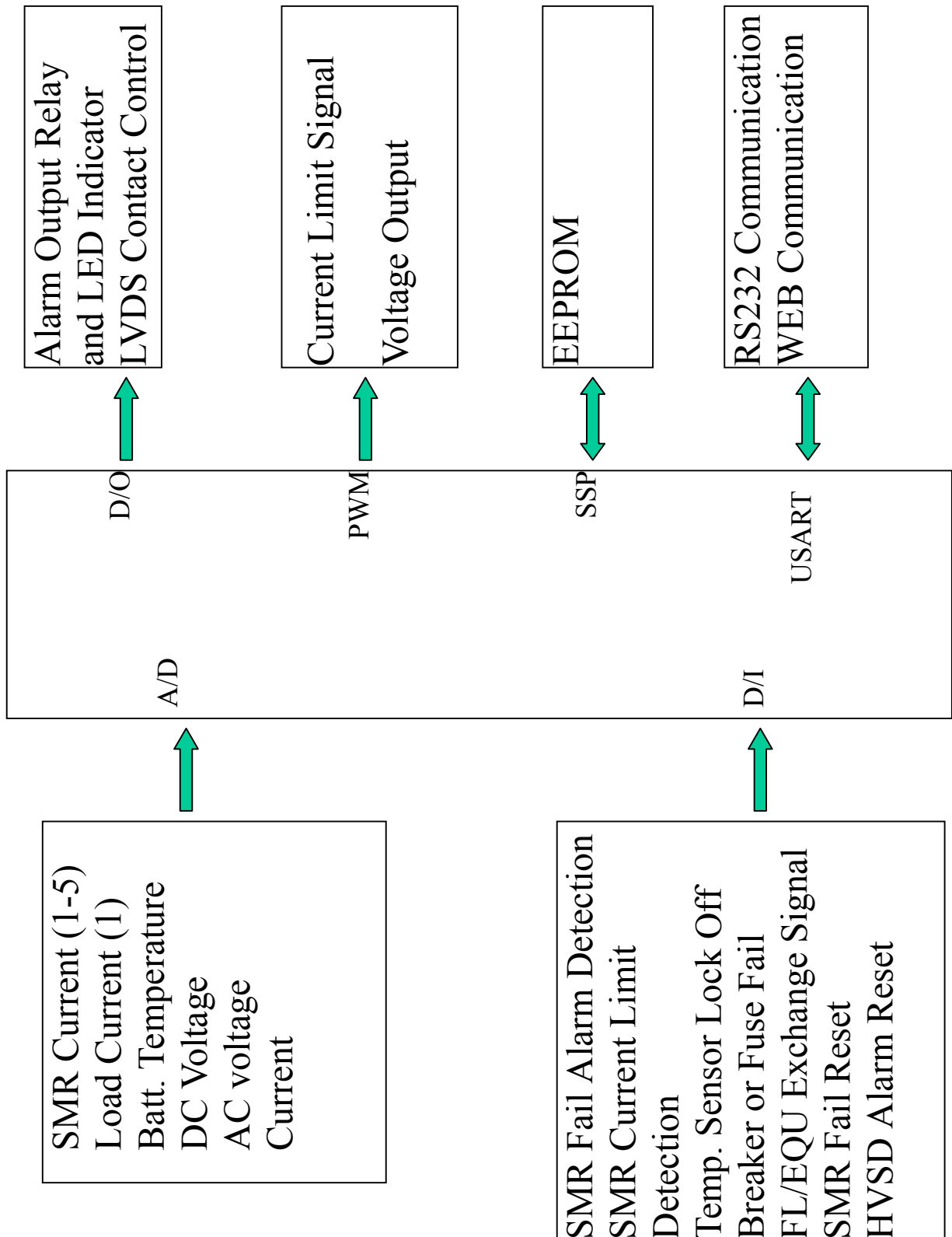
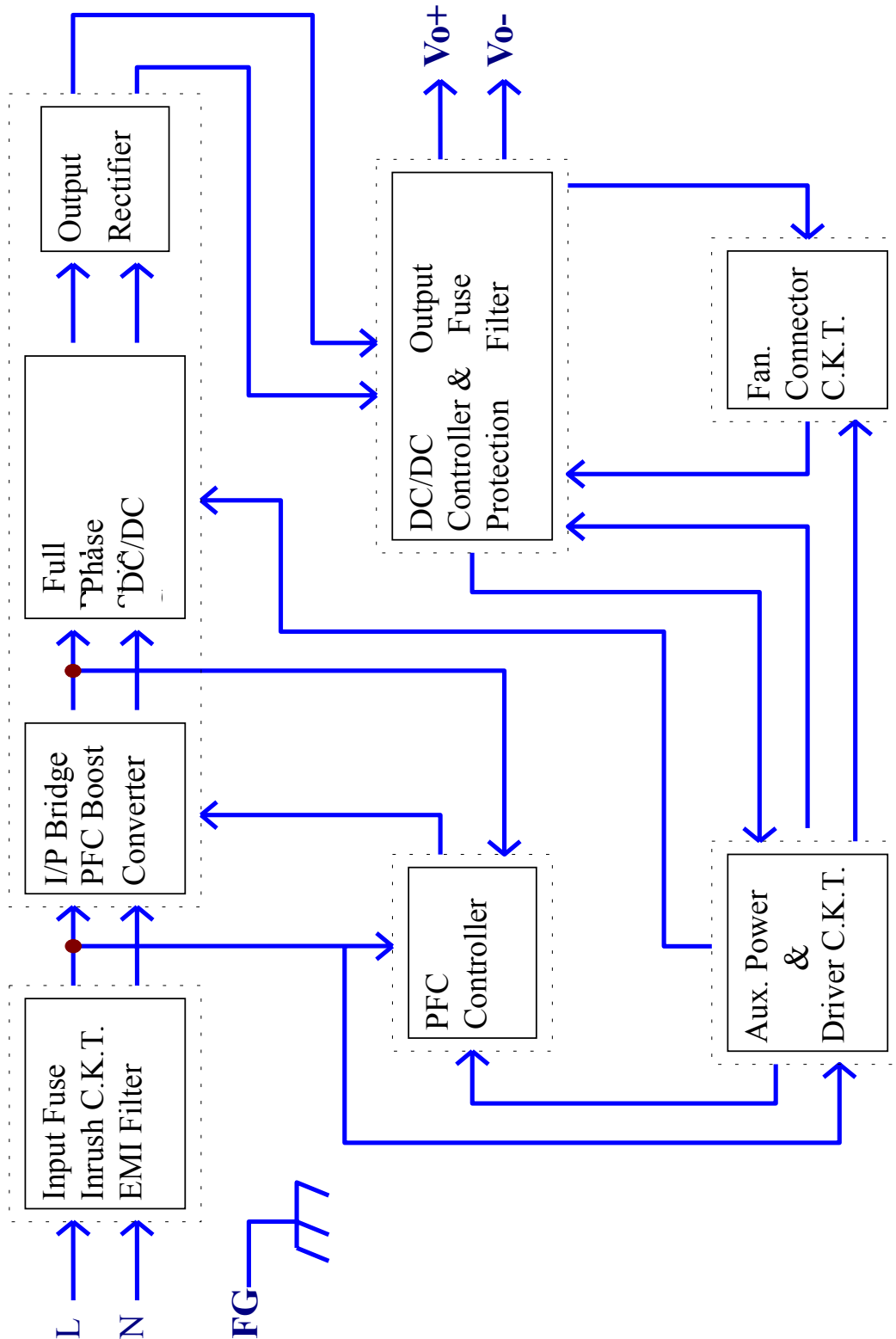

Figure 7: SMR Block Diagram





TAIPEI OFFICE

186 RUEY KUANG ROAD, NEIHU
TAIPEI 114, TAIWAN, R.O.C.
TEL : 886-2-87972088
FAX : 886-2-87972120

CHUNGLI PLANT

3 TUNG YUAN ROAD,
CHUNGLI INDUSTRIAL ZONE,
CHUNGLI, TAOYUAN HSIEN 320, TAIWAN, R.O.C.
TEL. 886-3-4526107
FAX. 886-3-4527314

P/N: MCS-1800 Power Shelf